

输入交流电抗器  
AC Input Reactor (Choke)

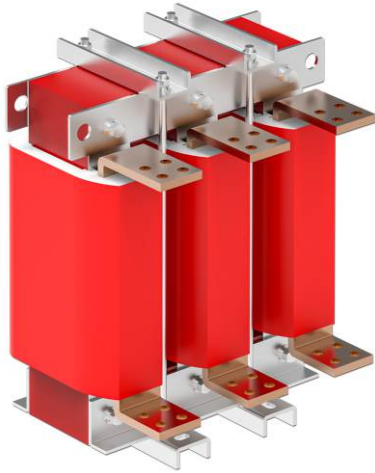

Product Profile 产品简述

In application at AC drive input side to suppress inrush voltage. Reduce inrush & peak current; Improve the real power factor, restrain the grid harmonics and Improve the input current waveform.

输入电抗器是限流设备，用于驱动器的输入侧，保护交流驱动器不受瞬态超压的影响。降低浪涌和峰值电流，提高真实功率因数，抑制电网谐波，改善输入电流波形。

Product Features 产品特点

Excellent property due to foil winding structure, small DC resistance. the resistance to electromagnetic force ability is strong, good overload ability in short time; F class insulation materials, so that products can maintain reliable performance capacity. Moreover, combined with VPI process, the reactor noise is low; Core with grain-oriented cold rolled silicon steel in harsh working conditions; Designed with low magnetic flux density, the reactors of high linearly, powerful overload sheets, the reactor boasts high efficiency, low temperature rise and low loss.

采用了高性能的箔式绕组结构，具有电流电阻小，抗短路能力强，短时间过载能力强；采用高性能的F级以上的复合绝缘材料，使产品在严酷的工作条件下依然可以保持可靠的性能；电抗器设计磁通密度低，线性度好，过载能力强，配合真空压力浸渍工艺电抗器的噪音小；铁芯采用优质低损耗冷轧取向硅钢片，电抗器损耗小，效率高，温升低。

Product Parameters 产品参数

|                               |  |
|-------------------------------|--|
| Rated Operating Voltage       | 380V/690V/1140V 50Hz/60Hz  |
| Operating Frequency           | 50/60Hz  |
| Current Range                 | 5A to 1600A  |
| Operation Ambient Temperature | -25°C ~ 50°C   |
| Dielectric Strength           | Core-Winding, AC 3000V/50Hz/5mA in 60s free of damage(test in factory)                 |
| Insulation Resistance         | Core-Winding, DC 1000V, Resistance >100M ohm   |
| Reactor's noise               | less than 65dB(to be measured at the point 1 meter away from the reactor horizontally) |
| Protection class              | IP00   |
| Insulation class              | F/H  |
| Standard                      | GB 19212.1-2008 GB/T 1094.6-2011   |

|        |  |
|--------|--|
| 额定工作电压 | 380V/690V/1140V 50Hz/60Hz                |
| 工作频率   | 50/60Hz                                  |
| 额定工作电流 | 5A 至 1600A                               |
| 工作环境温度 | -25°C ~ 50°C                             |
| 抗电强度   | 铁芯-绕组 AC 3000V/50Hz/5mA, 60秒无飞弧击穿 (工厂测试) |
| 绝缘电阻   | DC 1000V, 绝缘阻值 ≥ 100MΩ                   |
| 电抗器噪音  | <65dB (与电抗器水平距离1米测试)                     |
| 防护等级   | IP00                                     |
| 绝缘等级   | F级/H级                                    |
| 产品执行标准 | GB 19212.1-2008 GB/T1094.6-2011          |

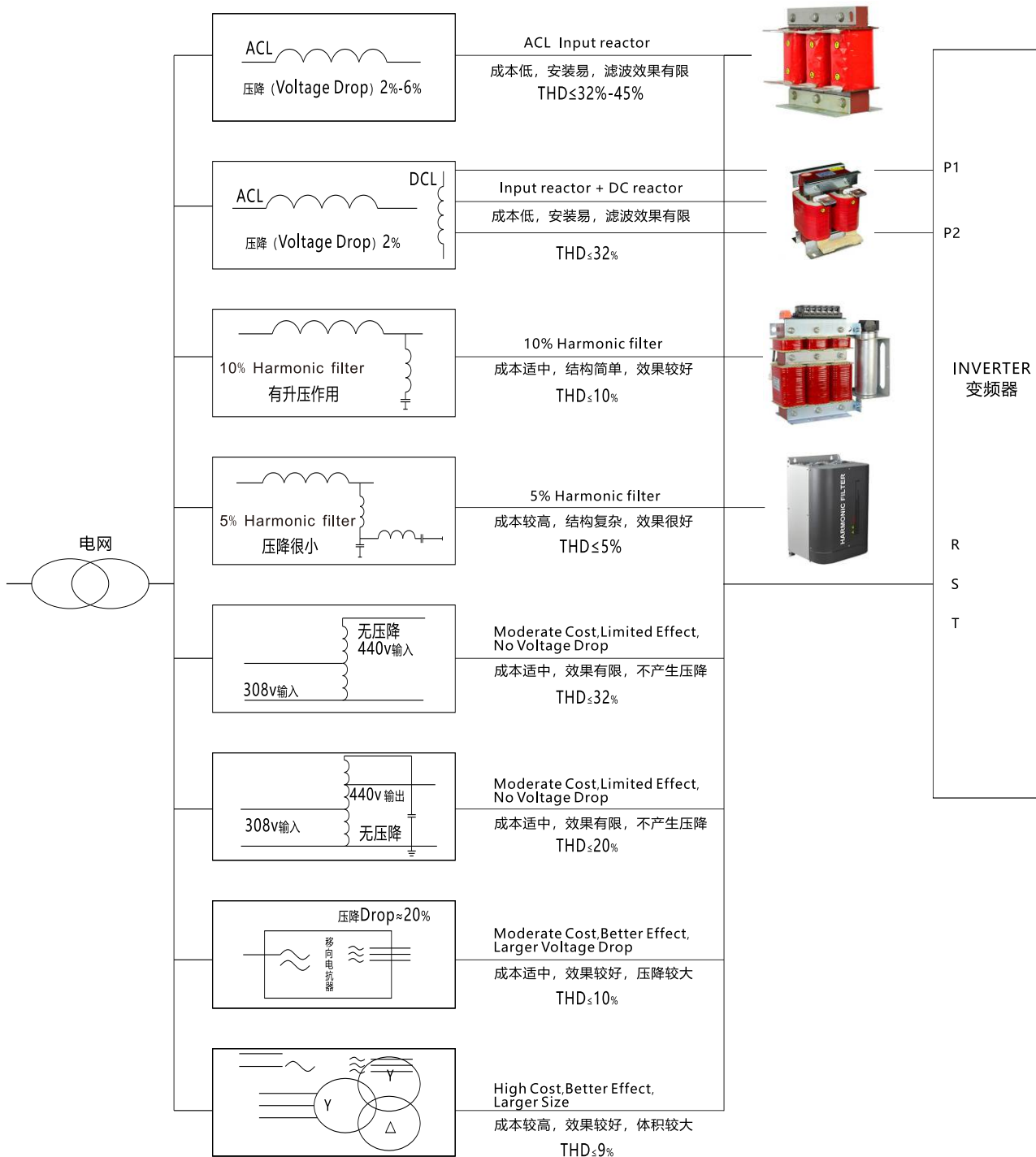

## 380V AC input reactor (2% impedance) selection table 380V输入交流电抗器 (2%电抗率) 选型表

| Type<br>电抗器型号       | Power<br>功率(Kw) | Inductance<br>Value<br>电感量(mH) | Current<br>电流(A) | Weight<br>重量(Kg) | Dimension 尺寸(mm) |      |      |      |      |      |         |       | Connection     |               | Linear<br>aperture<br>线排孔径 | Pic. NO.<br>图号 |
|---------------------|-----------------|--------------------------------|------------------|------------------|------------------|------|------|------|------|------|---------|-------|----------------|---------------|----------------------------|----------------|
|                     |                 |                                |                  |                  | D(Max)           | D1±1 | D2±2 | W±10 | W1±1 | W2±2 | H (Max) | A*B   | Terminal<br>端子 | Cu flat<br>铜排 |                            |                |
| VKS-ACL-0005-CL/4-2 | 1.5             | 2.80                           | 5                | 1.7              | 100              | 35   | 80   | /    | 59   | 77   | 125     | 7x12  | √              |               | /                          | A              |
| VKS-ACL-0007-CL/4-2 | 2.2             | 2                              | 7                | 1.8              | 100              | 35   | 80   | /    | 59   | 77   | 125     | 7x12  | √              |               | /                          | A              |
| VKS-ACL-0010-CL/4-2 | 3.7             | 1.4                            | 10               | 1.85             | 100              | 35   | 80   | /    | 59   | 77   | 125     | 7x12  | √              |               | /                          | A              |
| VKS-ACL-0015-AL/4-2 | 5.5             | 0.93                           | 15               | 2.5              | 150              | 70   | 120  | /    | 72   | 92   | 150     | 7x12  | √              |               | /                          | A              |
| VKS-ACL-0020-AL/4-2 | 7.5             | 0.70                           | 20               | 2.5              | 150              | 70   | 120  | /    | 72   | 92   | 150     | 7x12  | √              |               | /                          | A              |
| VKS-ACL-0030-AL/4-2 | 11              | 0.47                           | 30               | 3.5              | 180              | 70   | 145  | /    | 68   | 88   | 170     | 7x12  | √              |               | /                          | A              |
| VKS-ACL-0040-AL/4-2 | 15              | 0.35                           | 40               | 5                | 180              | 70   | 145  | /    | 81   | 101  | 170     | 7x12  | √              |               | /                          | A              |
| VKS-ACL-0050-AL/4-2 | 18.5            | 0.28                           | 50               | 5                | 180              | 70   | 145  | 130  | 81   | 101  | 135     | 7x12  | √              |               | /                          | B              |
| VKS-ACL-0060-AL/4-2 | 22              | 0.24                           | 60               | 6.5              | 180              | 70   | 145  | 140  | 90   | 110  | 145     | 7x12  | √              |               | /                          | B              |
| VKS-ACL-0080-AL/4-2 | 30              | 0.17                           | 80               | 9                | 210              | 80   | 170  | 155  | 91   | 111  | 160     | 7x12  | √              |               | /                          | B              |
| VKS-ACL-0090-AL/4-2 | 37              | 0.16                           | 90               | 9                | 210              | 80   | 170  | 155  | 91   | 111  | 160     | 7x12  | √              |               | /                          | B              |
| VKS-ACL-0120-AL/4-2 | 45              | 0.12                           | 120              | 13               | 245              | 80   | 200  | 160  | 94   | 130  | 210     | 12x20 |                | 30*3          | φ11                        | C              |
| VKS-ACL-0150-AL/4-2 | 55              | 0.095                          | 150              | 15               | 245              | 80   | 200  | 160  | 94   | 130  | 210     | 12x20 |                | 30*3          | φ11                        | C              |
| VKS-ACL-0200-AL/4-2 | 75              | 0.07                           | 200              | 20               | 245              | 80   | 200  | 185  | 120  | 156  | 210     | 12x20 |                | 30*3          | φ11                        | C              |
| VKS-ACL-0240-AB/4-2 | 90              | 0.056                          | 240              | 25               | 240              | 180  | 200  | 195  | 132  | 162  | 220     | 11x20 |                | 30*7          | φ11                        | D              |
| VKS-ACL-0250-AB/4-2 | 110             | 0.056                          | 250              | 25               | 240              | 180  | 200  | 195  | 132  | 162  | 220     | 11x20 |                | 30*7          | φ11                        | D              |
| VKS-ACL-0290-AB/4-2 | 132             | 0.048                          | 290              | 31               | 310              | 225  | 250  | 215  | 122  | 158  | 255     | 12x20 |                | 40*8          | φ13                        | E              |
| VKS-ACL-0330-AB/4-2 | 160             | 0.042                          | 330              | 34               | 310              | 225  | 250  | 215  | 122  | 158  | 255     | 12x20 |                | 40*8          | φ13                        | E              |
| VKS-ACL-0390-AB/4-2 | 187             | 0.036                          | 390              | 42               | 310              | 225  | 250  | 220  | 125  | 161  | 285     | 12x20 |                | 40*8          | φ13                        | E              |
| VKS-ACL-0490-AB/4-2 | 220             | 0.028                          | 490              | 42               | 310              | 225  | 250  | 220  | 125  | 161  | 285     | 12x20 |                | 40*8          | φ13                        | E              |
| VKS-ACL-0530-AB/4-2 | 250             | 0.026                          | 530              | 42.5             | 310              | 225  | 250  | 220  | 125  | 161  | 285     | 12x20 |                | 40*8          | φ13                        | E              |
| VKS-ACL-0600-AB/4-2 | 280             | 0.023                          | 600              | 55               | 310              | 225  | 250  | 245  | 145  | 181  | 280     | 12x20 |                | 40*9          | φ13                        | E              |
| VKS-ACL-0660-AB/4-2 | 315             | 0.021                          | 660              | 55               | 310              | 225  | 250  | 245  | 145  | 181  | 280     | 12x20 |                | 40*9          | φ13                        | E              |
| VKS-ACL-0800-AB/4-2 | 380             | 0.0175                         | 800              | 85               | 390              | 130  | 320  | 305  | 230  | 270  | 400     | 12x20 |                | 50*11         | 2-φ11                      | G              |
| VKS-ACL-1000-AB/4-2 | 450             | 0.014                          | 1000             | 85               | 390              | 130  | 320  | 305  | 230  | 270  | 400     | 12x20 |                | 50*11         | 2-φ11                      | G              |
| VKS-ACL-1250-AB/4-2 | 550             | 0.011                          | 1250             | 110              | 385              | 130  | 320  | 305  | 210  | 250  | 470     | 12x20 |                | 60*13         | 4-φ13                      | F              |
| VKS-ACL-1600-AB/4-2 | 630             | 0.009                          | 1600             | 110              | 385              | 130  | 320  | 305  | 210  | 250  | 470     | 12x20 |                | 60*15         | 4-φ13                      | F              |

Note/备注: (1) Picture C公差(Tolerance) D:max D1:±1 D2±2 W:max W1:±2 W2:±2 H:max H1:±5 H2:±5 E±10,其余未注公差(others)±0.5mm;  
Picture D公差(Tolerance) D:max D1:±1 D2±2 W:max W1:±2 W2:±2 H:max H1:±5 H2:±5 E±10,其余未注公差(others)±0.5mm.  
(2) Can be customized. 以上型号为我司标准品, 其它规格可以根据客户要求定制。  
(3) Class H Can be customized. H级产品可以根据客户要求定制。

## Product Size 产品尺寸图

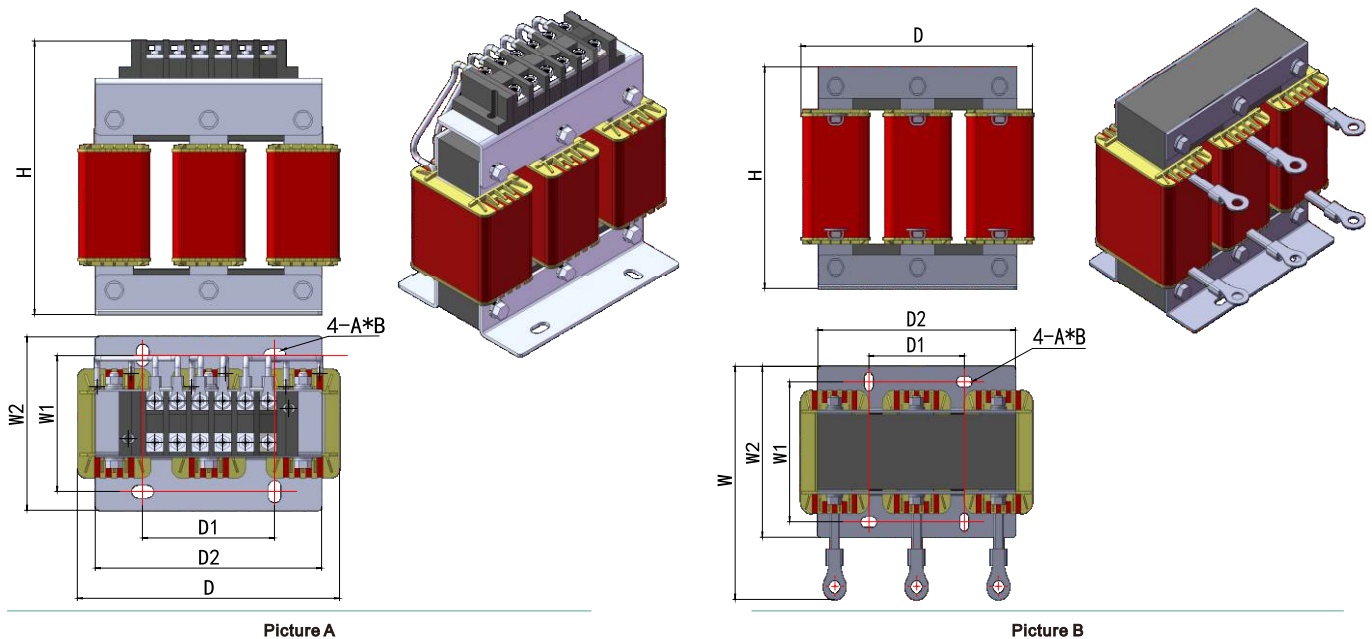

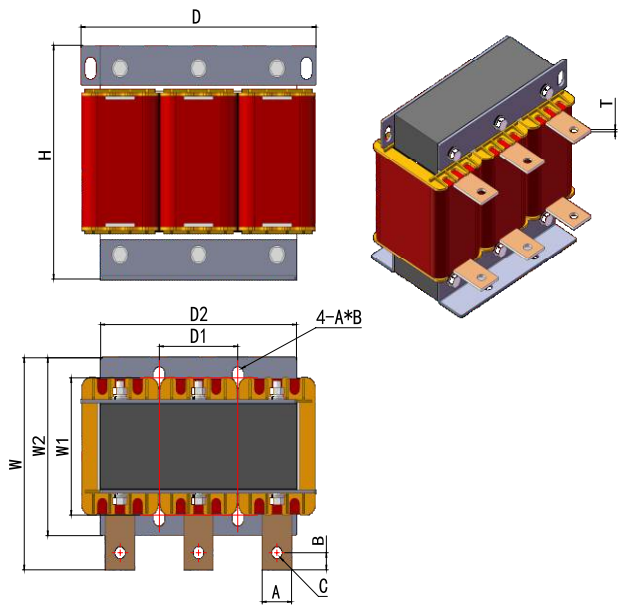

Picture C

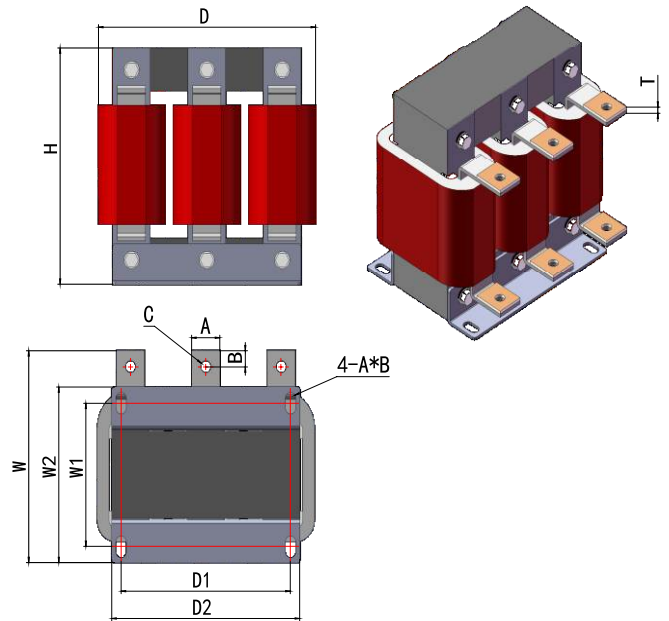

Picture D

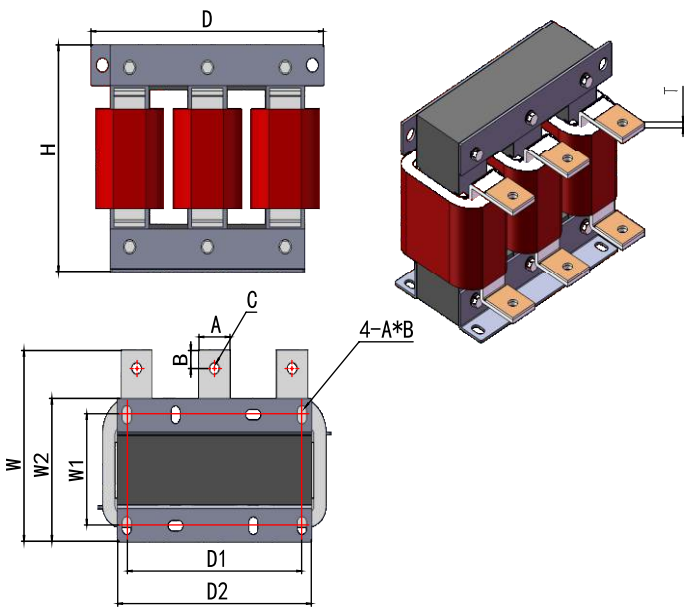

Picture E

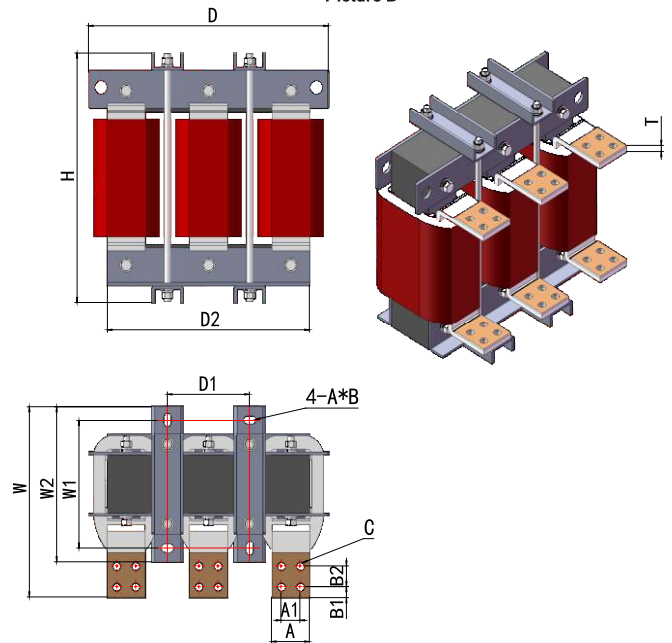

Picture F

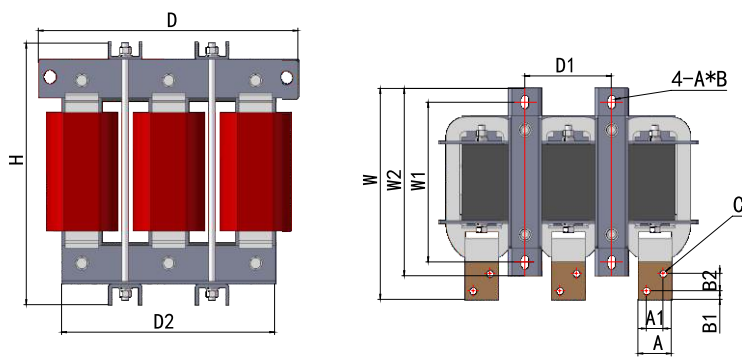

Picture G

Observe protection clause to ISO 16016

请遵守 ISO 16016 的保密条款

DATE: 29.09.2020