

User's Manual

Motor soft starters **Built-in Bypass Motor Soft Starter**

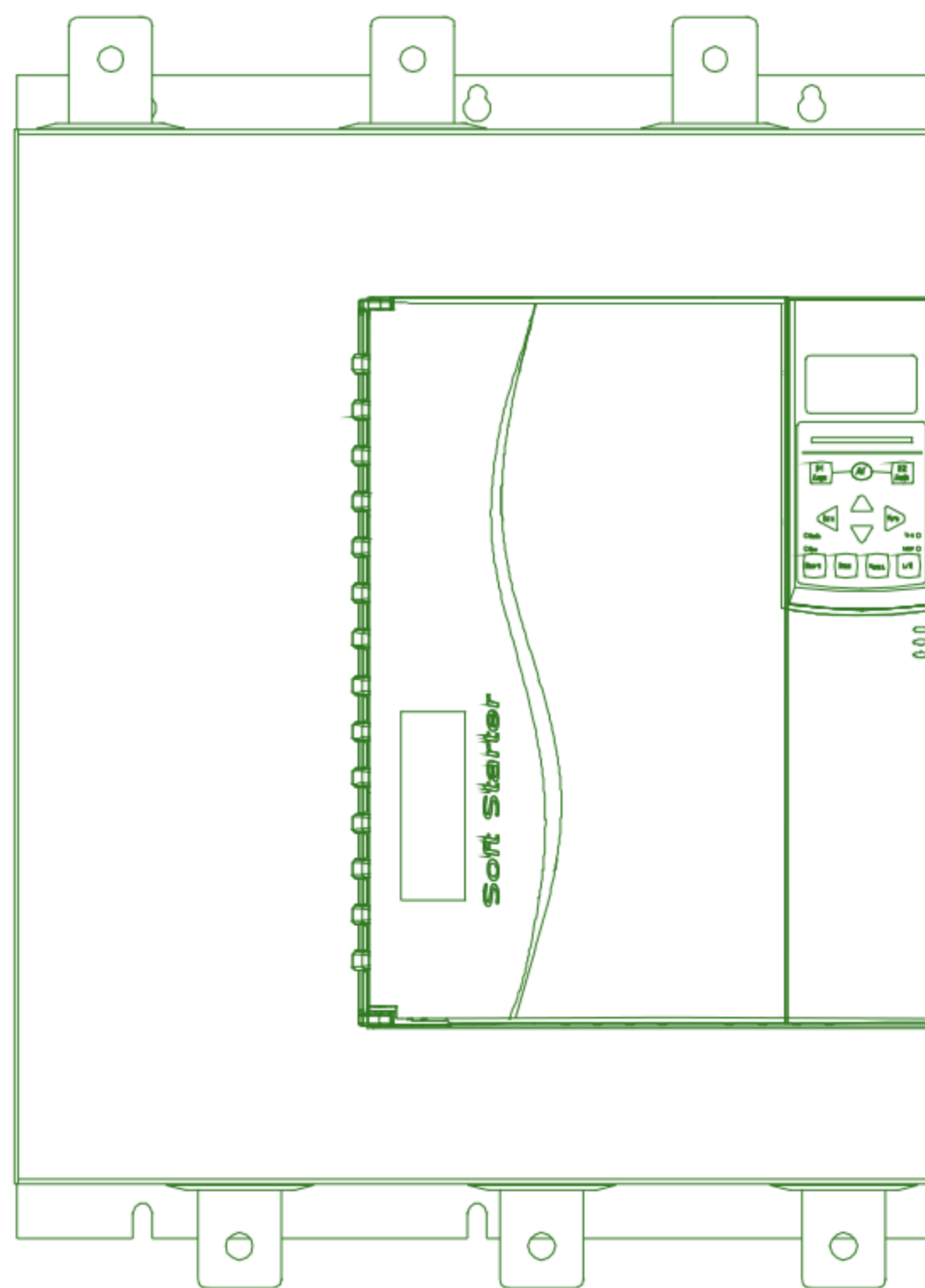
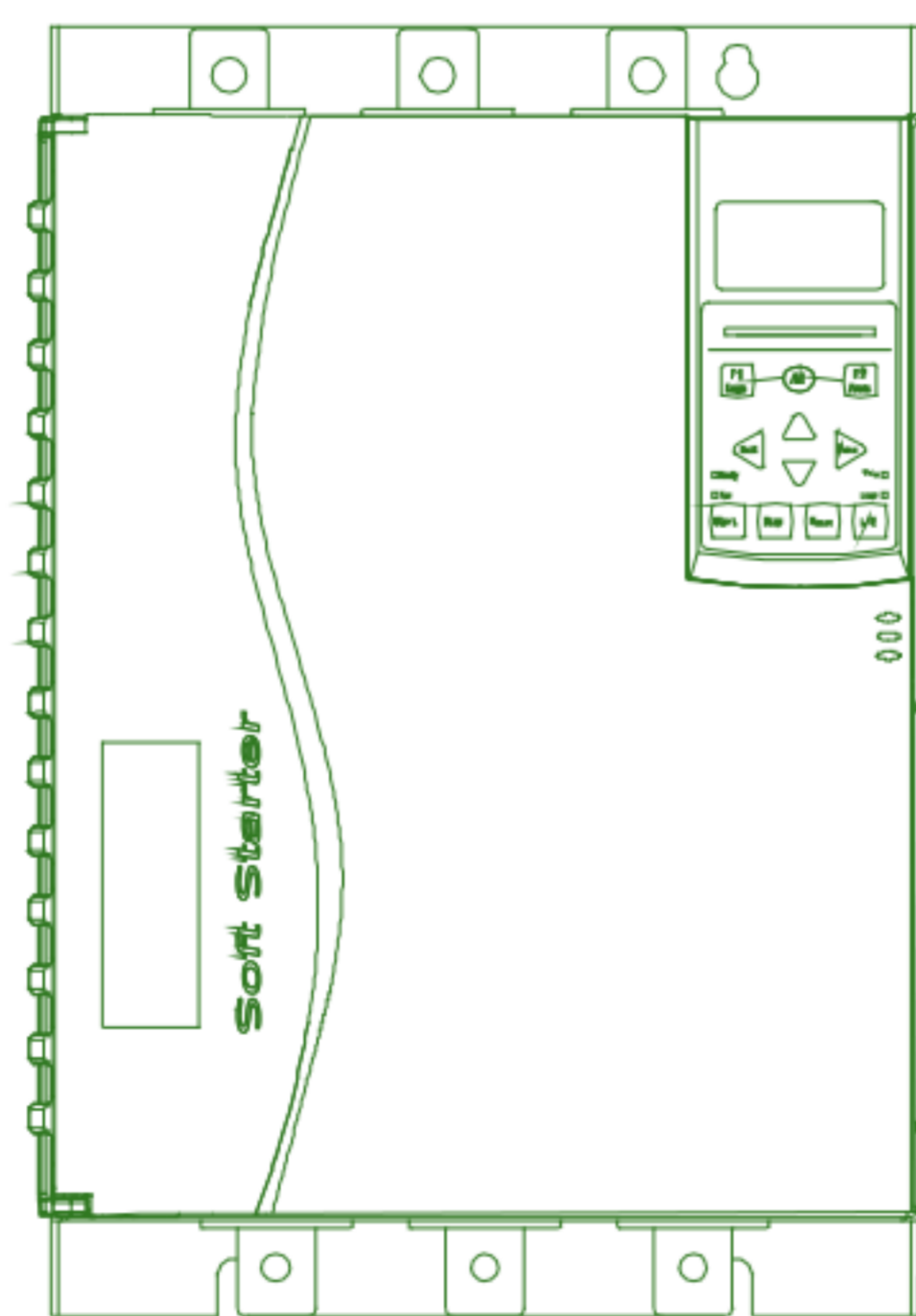
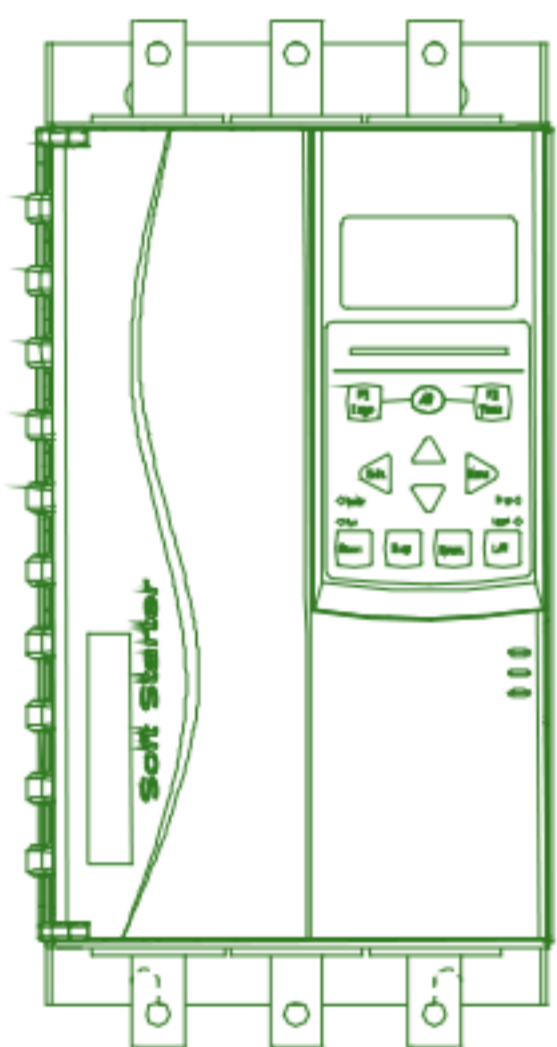

Chapter 1 Caution Statement	01
1.1 Electric Shock Hazard	01
1.2 Disposal Instructions	02
Section 2 Introduction	03
2.1 Feature List	03
Chapter 3 Basic Settings	04
3.1 Setting procedure summary	04
3.2 Testing Equipment Installation	04
3.3 Simulation Tool	04
Chapter 4 Installation	05
4.1 Physical Installation	05
4.2 Control Terminal	05
4.3 Control Voltage	05
4.4 Control Cable	06
4.5 Relay Output	06
4.6 Motor Thermistor	06
4.7 Earthing Terminal	07
4.8 Power Supply Input And Output Configuration	07
4.9 Power Connection	08
4.10 Principle Chart	09
Chapter 5 Power Supply Circuit	10
5.1 Electric Motor Connection	10
5.2 Bypass Contactor	12
5.3 Main Contactor	12
5.4 Circuit Breaker	12
5.5 Power Factor Correction	12
Chapter 6 Operation Board And Feedback	13
6.1 Operation Panel	13
6.2 Display	14
Chapter 7 Repairing Tool	15
7.1 Test Device Installation	15
7.2 Degug Menu	15
7.3 Log Menu	15
Chapter 8 Operation	16
8.1 Start, Stop and Reset Commands	16
8.2 Soft Start Method	16
8.3 Stop Method	19
8.4 Jog Operation	20

Chapter 9 Programming Menu	21
9.1 Programming Menu	21
9.2 Parameter Write Protection	21
9.3 Basic parameters	22
9.4 Protection parameters	23
9.5 Protection level	23
9.6 Calibration function	24
9.7 Additional function	24
9.8 Status information	25
9.9 Display parameters	25
9.10 Parameter description	26
Chapter 10 Troubleshooting	38
10.1 Protection response	38
10.2 Trip message	38
Chapter 11 Function Description	40
11.1 Overload protection	40
10.2 Current arrival	41
10.2 Current arrival	42
12.1 Specifications	42

Section 1 Caution Statements



The use of this symbol in this manual reminds the reader to pay special attention to special precautions regarding the installation and operation of the equipment.

Caution Statements cannot cover every potential cause of equipment damage but can highlight common causes of damage. It is the installer's responsibility to read and understand all instructions in this manual prior to installing, operating or maintaining the soft starter, to follow good electrical practice including applying appropriate personal protective equipment and to seek advice before operating this equipment in a manner other than as described in this manual.



NOTE

The user cannot repair the soft starter. The soft starter should only be repaired by authorized service personnel. Unauthorized modification of the starter will void the product warranty.

1.1 Electrical Shock Risk

The voltages present in the following locations can cause severe electric shock and may be lethal:

- AC supply cables and connections
- Output cables and connections
- Many internal parts of the starter, and external option units

The AC supply must be disconnected from the starter using an approved isolation device before any cover is removed from the starter or before any servicing work is performed.



WARNING DANGER OF ELECTRIC SHOCK

132kW and above: As long as the power supply voltage is connected (including when the starter trips or waits for a command), the bus and radiator must be regarded as charged.



SHORT CIRCUIT

It cannot prevent short circuit. After severe overload or short circuit occurs, the operation of soft start should be fully tested by an authorized service agent.



GROUNDING AND BRANCH CIRCUIT PROTECTION

It is the responsibility of the user or person installing the soft starter to provide proper grounding and branch circuit protection according to local electrical safety codes.



FOR YOUR SAFETY

- The STOP function of the soft starter does not isolate dangerous voltages from the output of the starter. The soft starter must be disconnected by an approved electrical isolation device before accessing electrical connections.
- Soft starter protection features apply to motor protection only. It is the user's responsibility to ensure safety of personnel operating machinery.
- In some installations, accidental starts may pose an increased risk to safety of personnel or damage to the machines being driven. In such cases, it is recommended that the power supply to the soft starter is fitted with an isolating switch and a circuit-breaking device (eg power contactor) controllable through an external safety system (eg emergency stop, fault detector).
- The soft starter has built-in protections which can trip the starter in the event of faults and thus stop the motor. Voltage fluctuations, power cuts and motor jams may also cause the motor to trip.
- There is a possibility of the motor restarting after the causes of shutdown are rectified, which may be dangerous for certain machines or installations. In such cases, it is essential that appropriate arrangements are made against restarting after unscheduled stops of the motor.
- The soft starter is a component designed for integration within an electrical system; it is therefore the responsibility of the system designer/user to ensure the system is safe and designed to comply with relevant local safety standards. AuCom cannot be held accountable for any damages incurred if the above recommendations are not complied with.



AUTO- - START

Use the auto-start feature with caution. Read all the notes related to auto-start before operation.

The examples and diagrams in this manual are included solely for illustrative purposes. The information contained in this manual is subject to change at any time and without prior notice. In no event will responsibility or liability be accepted for direct, indirect or consequential damages resulting from the use or application of this equipment.

1.2 Disposal Instructions



Equipment containing electrical components may not be disposed of together with domestic waste.

It must be collected separately as electrical and electronic waste according to local and currently valid legislation.

Our company improving its products it reserves the right to modify or change the specification of its products at anytime without notice. The text, diagrams, images and any other literary or artistic works appearing in this document are protected by copyright. Users may copy some of the material for their personal reference but may not copy or use material for any other purpose without the prior consent of us. our company endeavors to ensure that the information contained in this document including images is correct but does not accept any liability for error, omission or differences with the finished product.

Section 2 Introduction

This soft starter is an advanced digital soft starter solution for motors with power from 11kW to 850kW. Provides a complete set of motor and system protection functions to ensure reliable performance even in the harshest installation environments.

2.1 Feature List

Optional soft start curve

- Voltage closed loop start
- Voltage open loop start
- Current closed loop start
- Current open loop start
- Torque start
- Direct start

Optional soft stop curve

- Free parking
- Timed soft parking
- DC brake parking

Expanded input and output options

- Remote control input
PT100 temperature sensor can be connected
- Relay output
- Analog output
- RS485 communication output

Easy-to-read display shows comprehensive feedback

- Removable operation panel
- Built-in Chinese + English display
- Built-in date and time display
- Work counter (start times, running hours)
- Performance monitoring (current, voltage, power factor, apparent power)
- User programmable monitoring screen

Customizable protection

- Motor overload
- Start timeout
- Undercurrent
- Current imbalance
- Input phase loss
- Output phase loss
- Soft starter overheated
- Motor overheated
- Phase sequence

Models that meet all connection requirements

- 22A-1000A (Rated)
- 200VAC-440VAC
- 380VAC-690VAC
- Internal bypass selection
- Star connection or delta connection

Advanced application optional features

- Ground fault protection
- DeviceNet、Modbus、Profibus、Ethernet
- (Ethernet IP、Modbus TCP、Profinet) Or USB communication module

Section 3 Basic Setting

3.1 Setting Procedure Summary



Warning

Do not apply power supply voltage to the starter before completing all cable connections.

1. Install the soft starter (refer to Chapter 4 Physical Installation for details.)
2. Connect the control cables (refer to 4.2 Control Terminals and 4.4 Control Cables for details).
3. Apply control voltage to the soft starter.
4. Set the date and time (according to parameter F19 for details).
5. Configure your application: A. Press ► MENU to open the "Menu". B. Press MENU again to enter "A Basic Parameters", and then press ► MENU to open the "A00 Application Selection" menu. C. Scroll to find your application in the list, and then press ► to start the configuration process (refer to parameter description A00 for details).
6. If your application is not in the "A00 application selection" list, set it in A basic parameters.
7. Press ◀ several times to close the "menu".
8. (Optional) Use the built-in simulation tool to check whether the control wiring is connected correctly (refer to Chapter 7 Maintenance Tools-Run Simulation).
9. Connect the power cable to the input terminals 1/L1, 3/L2, 5/L3 of the starter (refer to 4.8 Power Input and Output Configuration).
10. Connect the motor cable to the output terminals 2/T1, 4/T2, 6/T3 of the starter. The soft starter is now ready to control the motor.

3.2 Test equipment installation

You can connect the soft starter to a small motor for testing. During this test, the soft starter control input and relay output protection settings can be tested. This test mode is not suitable for testing soft start performance or soft stop performance.

3.3 Simulation tools

The software simulation function allows you to test the soft starter's working condition and control circuit when the soft starter is not connected to the power supply voltage.

- Run the simulation

Simulate the starting, running and stopping of the motor, and confirm that the soft starter and related equipment are installed correctly. Refer to Chapter 7 Maintenance Tools-Run Simulation for details.

Chapter 4 Installation

4.1 Physical installation

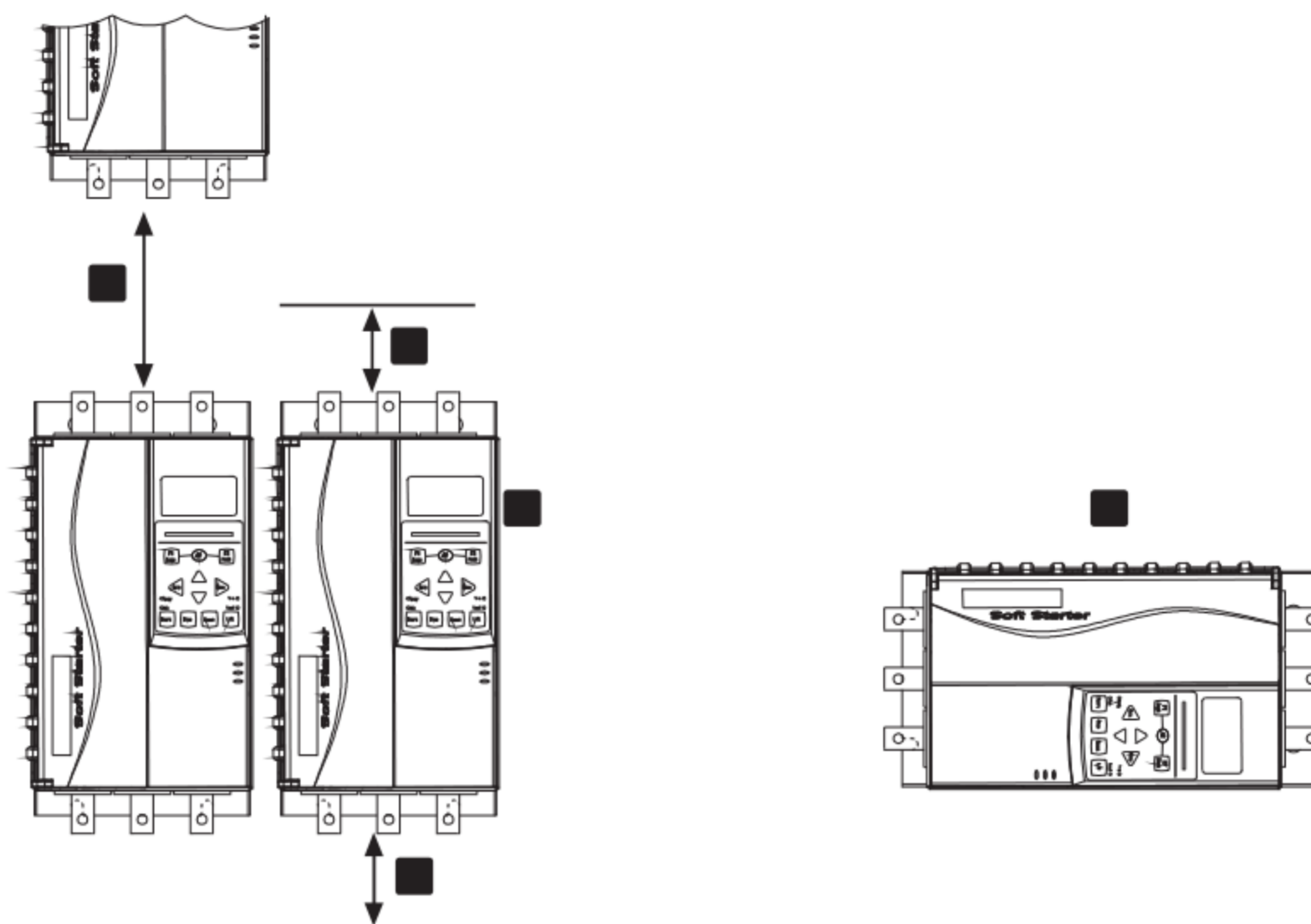

1	11kw~110kw: Allow 100mm (3.94 inches) between soft starters. 132kw~500kw: Allow 200mm (7.88 inches) between soft starters.
2	11kw~110kw: Allow 50 mm (1.97 inches) between the soft starter and the solid surface. 132kw~500kw: Allow 200 mm (7.88 inches) between the soft starter and the solid surface.
3	Soft starters can be installed side by side, leaving no gaps between each other (that is, no communication modules are installed).
4	The soft starter can be side mounted. The rated current of the soft starter is reduced by 15%.

4.2 Control terminal

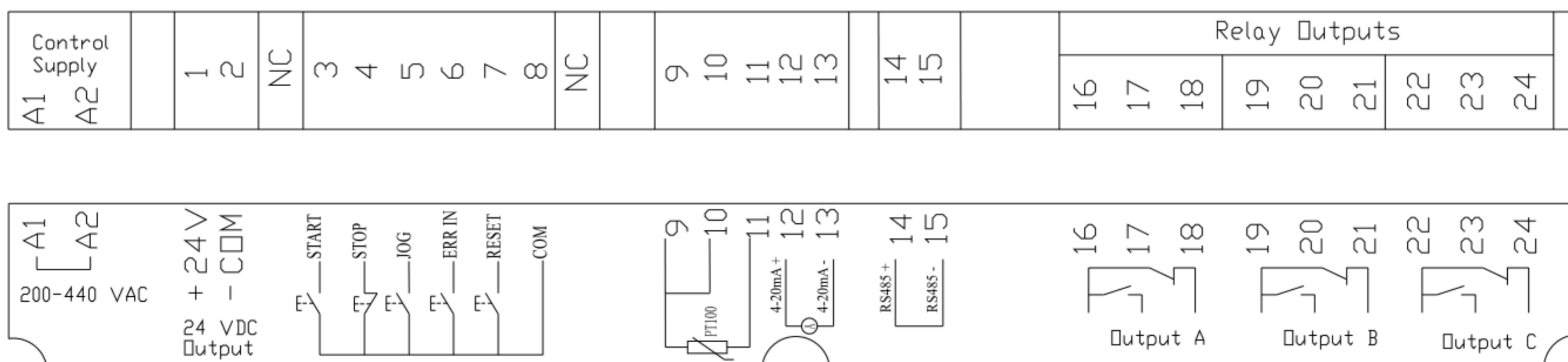

4.3 Control voltage

- (220~440 VAC) A1, A2

4.4 Control cable

The soft starter has three fixed remote control inputs. These inputs should be controlled by contacts with lower rated voltages and work under low current (gold-plated or similar materials).



Be careful

Do not apply voltage to the control input terminals. These are 24VDC active inputs and must be controlled by contacts without potential.

The cables connected to the control inputs must be separated from the power supply voltage and motor cables.

The reset input can be normally open or normally closed.

4.5 Relay output

The soft starter has three relay outputs, one of which is a fixed output and the other two are programmable outputs.

When the soft start is over, the running output is closed (starting current is lower than 120% of the programmed motor rated current), and it remains closed until it starts to stop (soft stop)

Or taxi to stop).

The settings of the parameters E00~E03 determine the action of the programmable output.

- If this output terminal is used to connect to the main contactor, when the soft starter receives the start command, this output terminal is activated and the soft starter controls The motor remains active during the process (until the motor enters the coasting stop state or the soft stop ends).
- If this output is used for the trip function, this output is activated when the trip occurs.
- If this output is used for instructions, activate this output when the designated instruction is activated.



Be careful

The switching capacity of the relay mounted on the PCB is not suitable for some electronic contactor coils. Consult with the contactor manufacturer/supplier to confirm

Its capacity.

4.6 Motor thermistor

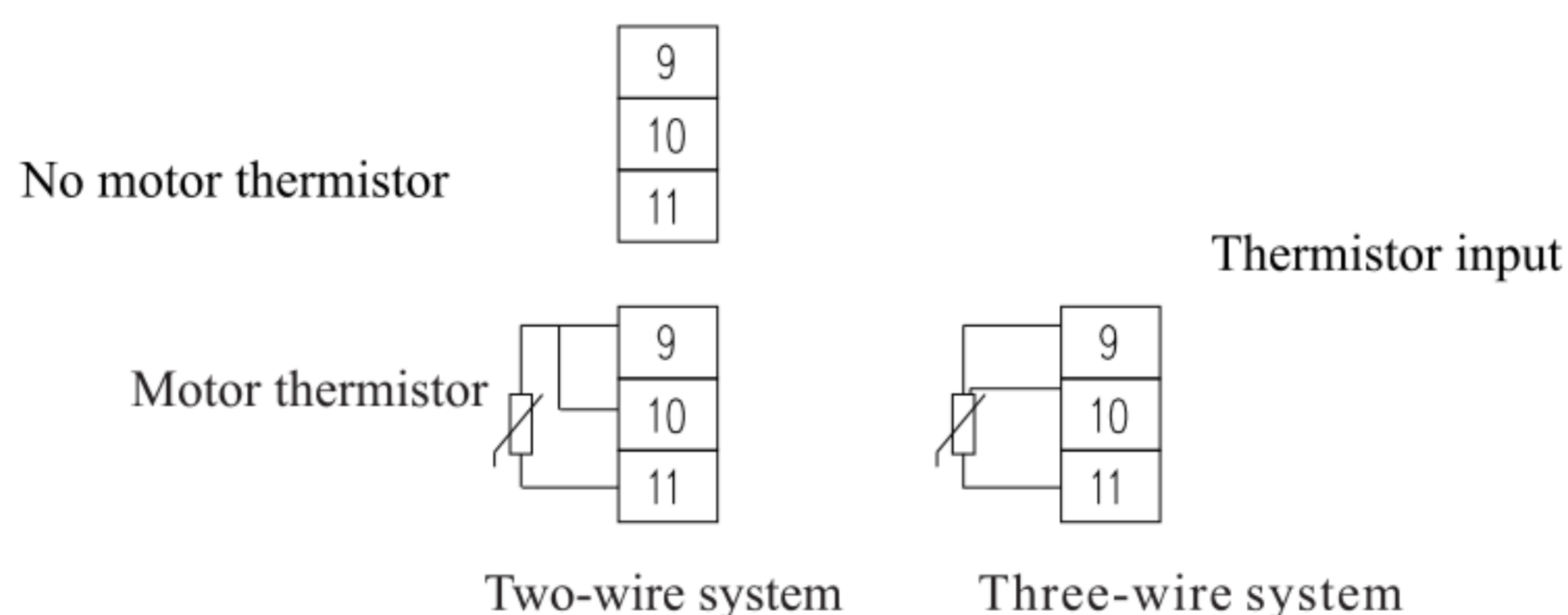

Attention



The protection level of the motor thermistor is "ignored" by default. If you want to enable the motor thermistor, you can use the parameter C11

If the machine is overheated, change the value to "trip and stop".

The thermistor circuit should use shielded cables, which must be electrically isolated from the ground wire, all other power circuits and control circuits.

4.7 Ground terminal

The ground terminal is located on the back of the soft starter.

- 11KW~55KW has a ground terminal (top) at the input end.
- 75KW~500KW has two grounding terminals, one of which is located at the input end (top), The other is located at the output end (bottom side).

4.8 Power input and output configuration

Connect the AC power supply in the form of top in and bottom out.

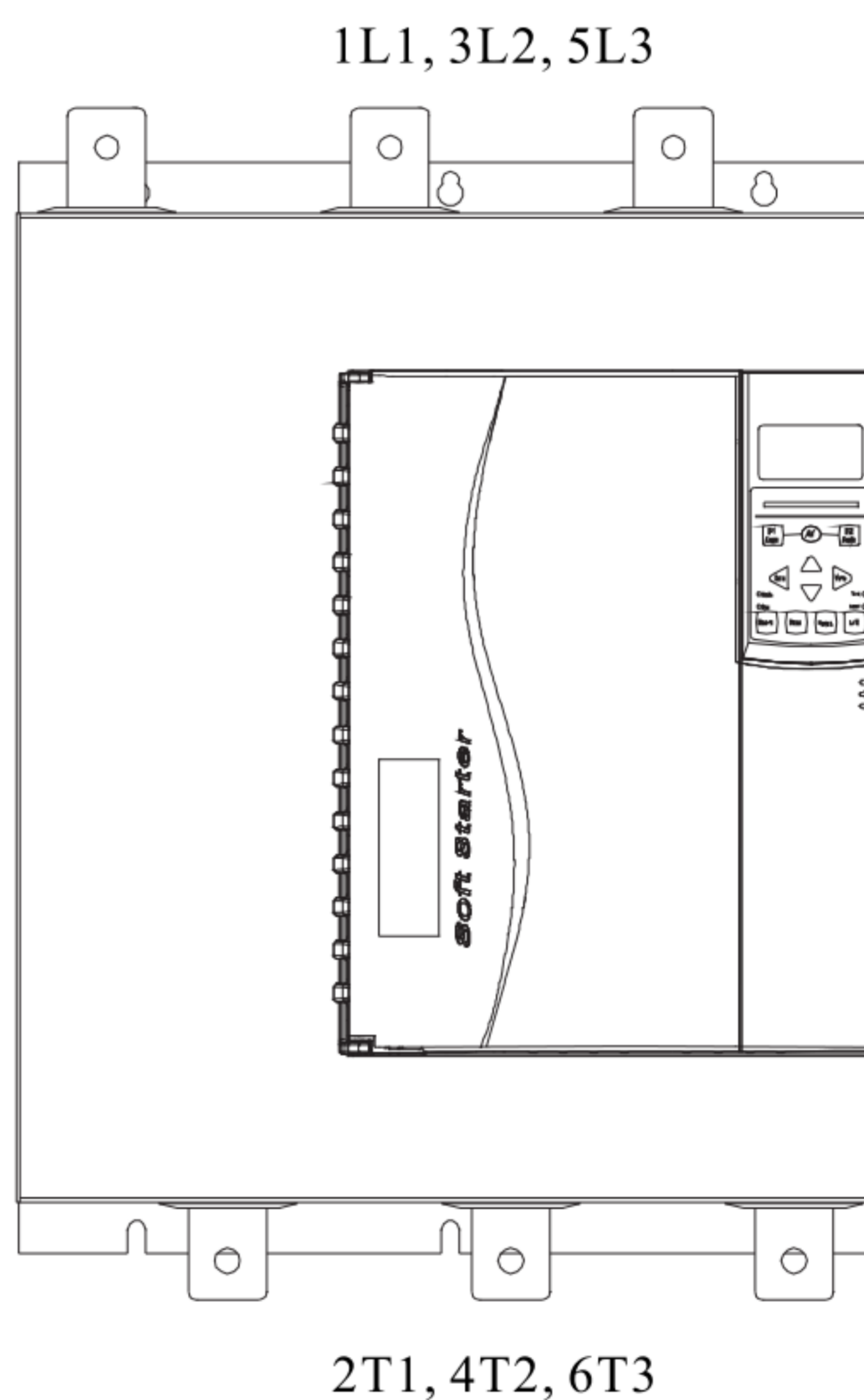
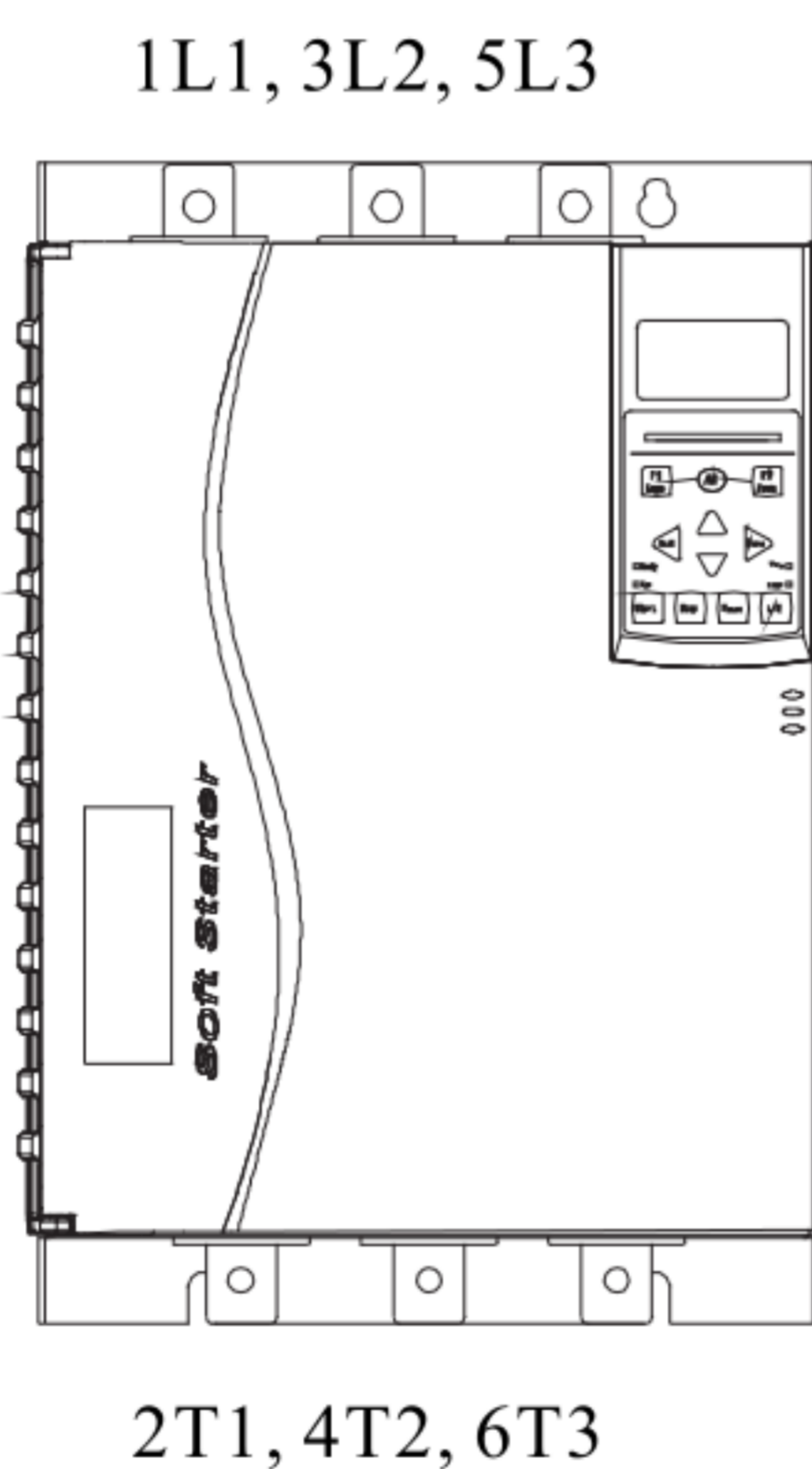
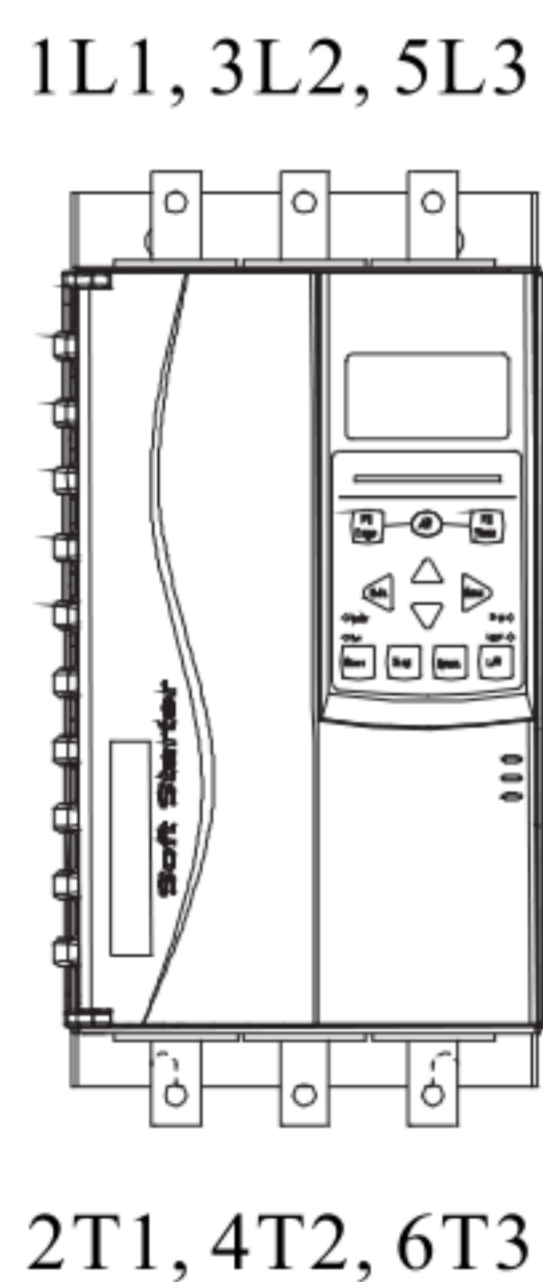

4.9 Power connection



Attention

When connecting the power supply, we recommend that you "use sandpaper or a stainless steel brush) to clean the contact surface thoroughly.

Copper stranded wire or solid wire.

11KW~55KW	75KW~110KW	132KW~500KW

4.10 Schematic

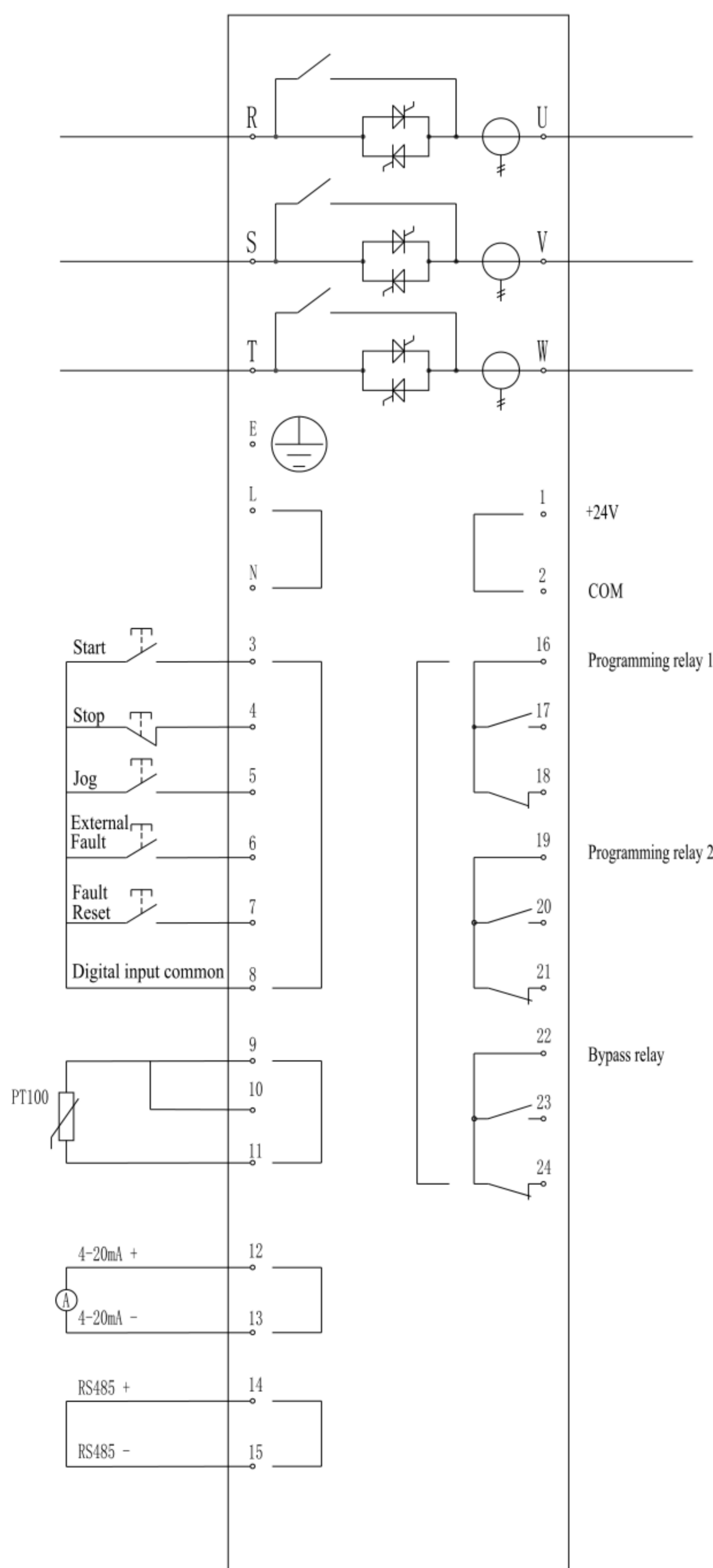

Terminal type	Terminal number	Terminal name	Description	
Master Back to Way	RST	Power input	Soft starter three-phase AC power input	
	UVW	Soft starter output	Connect three-phase asynchronous motor	
	R1S1T1	Bypass contactor terminal	Used to connect the bypass contactor. Only external The bypass type soft starter has this terminal, inside Set bypass type and thyristor on-line soft start Actuator without this terminal	
Power input	L	Power input L	220V-440V control power input	
	N	Power input N		
Control System Back to Way	24V output	1	+24V	DC 24V output, maximum current 100mA
		2	COM	
	Number Word Lose Out	3	Start	Can be started by short-circuiting with the common terminal (6) Moving soft starter
		4	Stop	Can be stopped when disconnected from the common terminal (6) Stop soft starter
		5	Moving point	Short-circuit with the common terminal (6) to jog Starting soft starter
		6	External fault	Short-circuit with common terminal (6) for soft start Shutdown
		7	Fault reset	Shorted to the common terminal (6) in case of failure Can clear the fault state
		8	Digital input common terminal	Digital input terminal common
	Analog input	9	Motor temperature sensor input A	Pt100
		10	Motor temperature sensor input B	
		11	Motor temperature sensor com	
	Analog output	12	4-20mA output positive	4-20mA output, 20mA corresponding current can pass Parameter E08, E09 adjustment
		13	4-20mA output negative	
	Communication	14	Rs485+	For ModBusRTU communication
		15	Rs485-	
Programming relay 1	16	Programming relay 1 common	Programmable output, you can choose from the following functions: 0. No action 1. Power on action 2. Soft start action 3. Bypass action 4. Action in soft stop 5. Action in jog 6. Action during operation 7. Standby action 8. Failure action 9. Thyristor breakdown action 10. The current is greater than the reached value 1 11. The current is greater than the reached value 2 12. The current is less than the reached value 1 13. The current is less than the reached value 2	
	17	Programming relay 1 normally open		
	18	Programming relay 1 normally closed		
Programming relay 2	19	Programming relay 2 common		
	20	Programming relay 2 normally open		
	21	Programming relay 2 normally closed		
Bypass relay	22	Bypass relay common	Pull-in during bypass operation	
	23	Bypass relay normally open		
	24	Bypass relay normally closed		

Control voltage:

- (220~440 VAC) A1, A2



Attention

The soft starter current transformer is located at the output.

Chapter 5 Power Circuit

5.1 Motor connection

The soft starter can use star connection method or delta connection method (also called three-wire connection method and six-wire connection method) to connect the motor. If the triangle connection method is used, use parameter F02 to input Enter the rated current of the motor.

Models with built-in bypass do not need to install an external bypass contactor.

Internal bypass type:

11kw、15kw、18.5kw、22kw、30kw、37kw

45kw、55kw、75kw、90kw、110kw、132kw、160kw、185kw

200kw、220kw、250kw、280kw、320kw、350kw、400kw

450kw、500kw

Star connection method, internal bypass

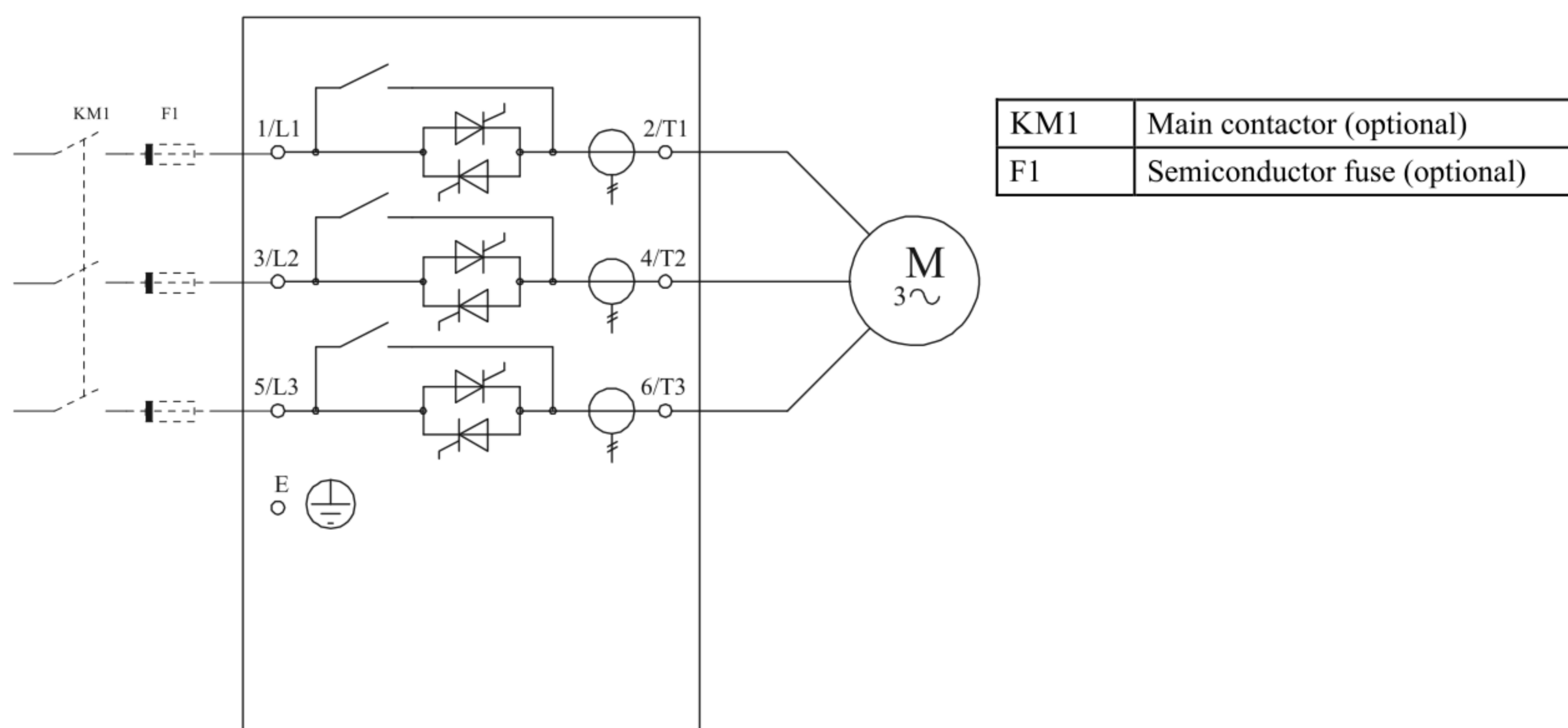

Star connection method, no bypass

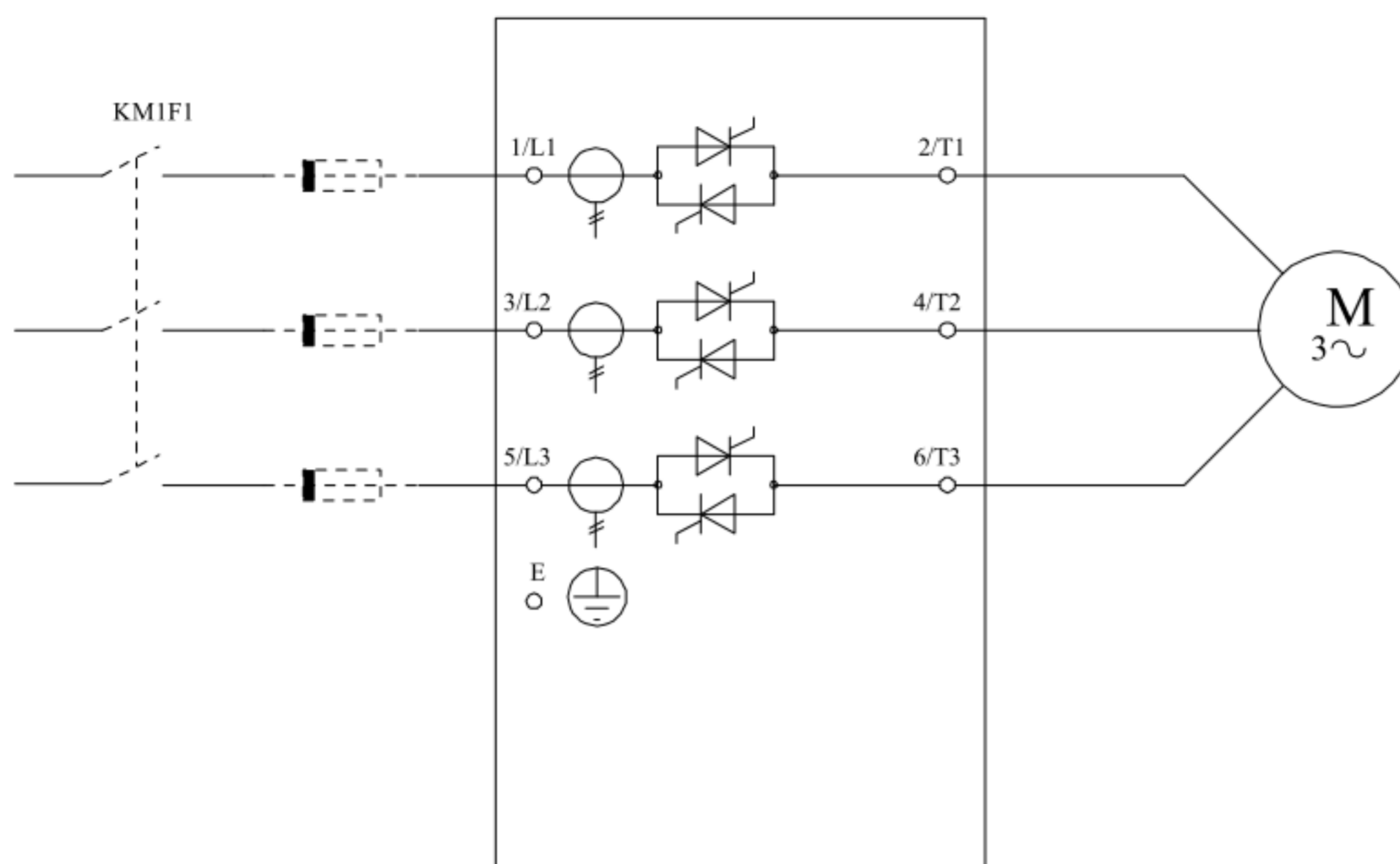

KM1	Main contactor (optional)
F1	Semiconductor fuse (optional)

Delta connection method, internal bypass

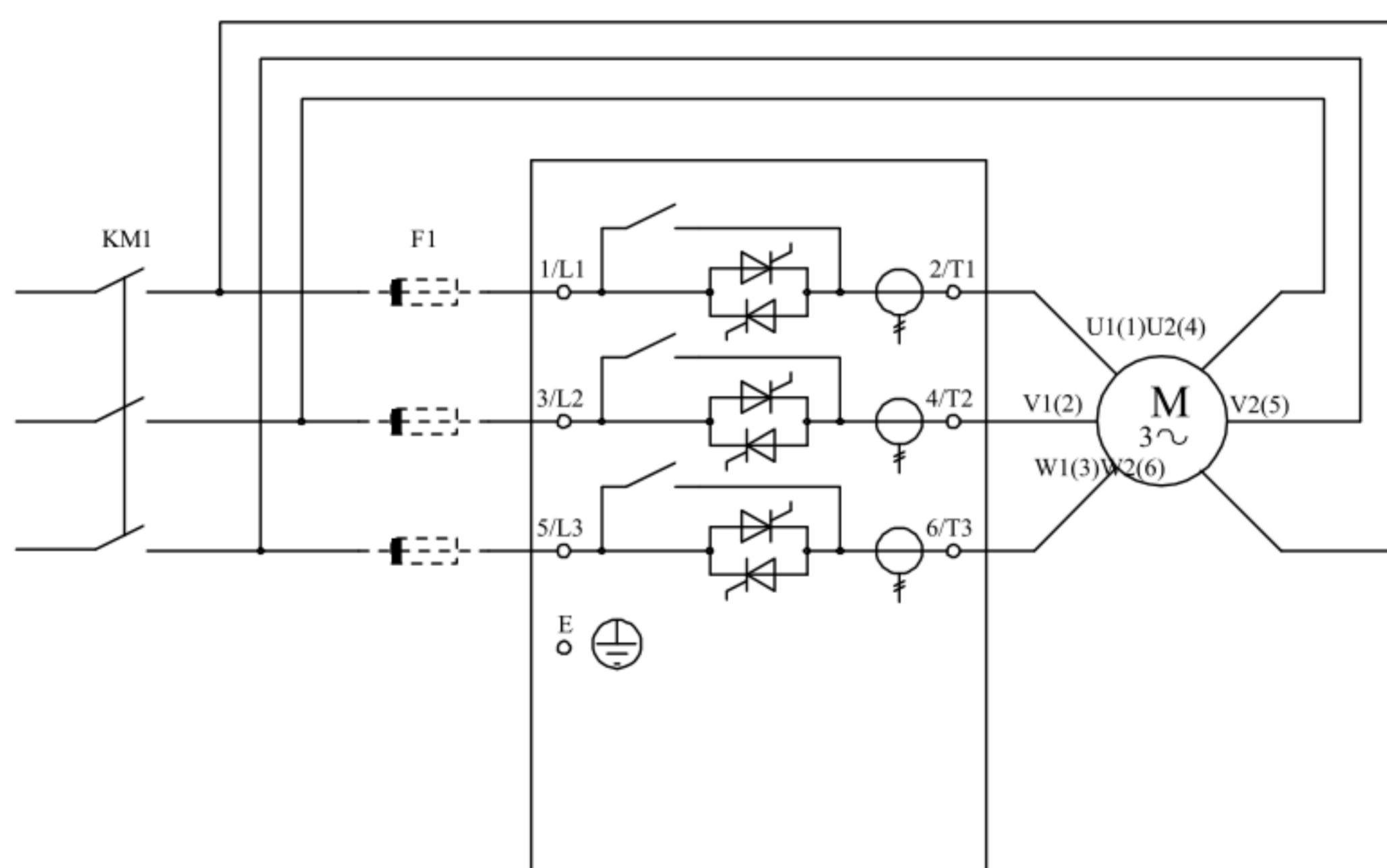

KM1	Main contactor
F1	Semiconductor fuse (optional)



Be careful

If the delta connection method is used to connect the soft starter, always install the main contactor or shunt trip circuit breaker.



Attention

If the delta connection method is adopted, use parameter F02 to input the rated current of the motor. Whether the soft starter adopts star connection method or delta
The connection method is modified by the parameter "E11 motor connection method".

Delta connection method, no bypass

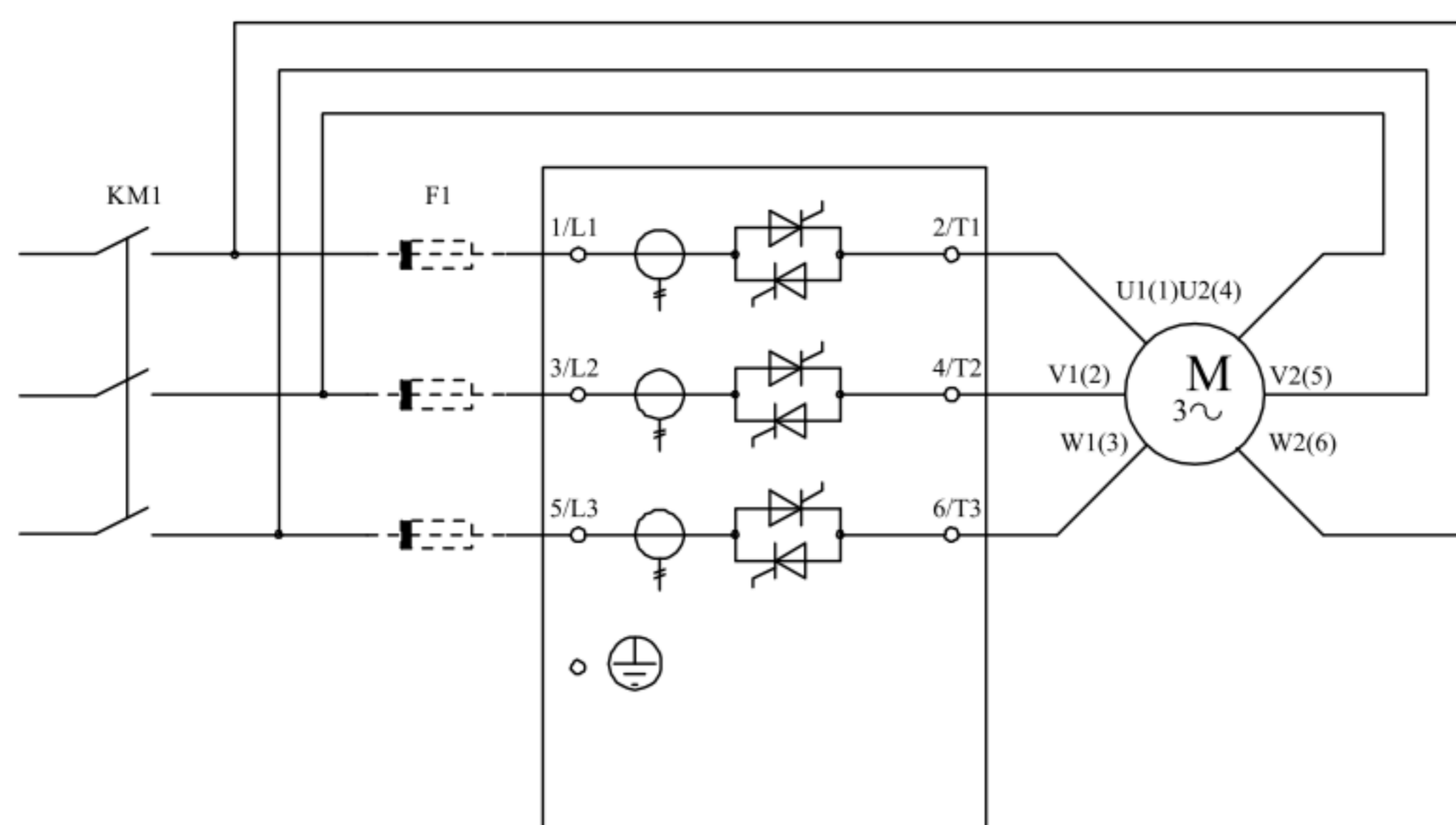

KM1	Main contactor
F1	Semiconductor fuse (optional)

5.2 Bypass contactor

Some soft starters have built-in bypass, no need to install an external bypass contactor.

Soft starters without built-in bypass may need to install an external bypass contactor. Select a contactor with an AC1 rating greater than or equal to the current rating of the connected motor.

Internal bypass type:

11kw、15kw、18.5kw、22kw、30kw、37kw

45kw、55kw、75kw、90kw、110kw、132kw、160kw、185kw

200kw、220kw、250kw、280kw、320kw、350kw、400kw

450kw、500kw

5.3 Main contactor

If the soft starter uses the delta connection method to connect the motor, the main contactor must be installed; if the star connection method is used, you can choose to install the main contactor.

Choose a contactor with an AC3 rating greater than or equal to the current rating of the connected motor.

5.4 Circuit breaker

A shunt trip circuit breaker can be used to disconnect the motor circuit when the soft starter trips, instead of using the main contactor.

The shunt trip mechanism must be powered by the power supply next to the circuit breaker

Power supply can also be powered by an independent control power supply.

5.5 Power factor correction

If power factor correction is used, a dedicated contactor should be used to switch capacitors.



Be careful

A power factor correction capacitor must be connected to the input end of the soft starter. If the power factor calibration is connected to the output end of the soft starter

Positive capacitors will damage the soft starter.

Chapter 6 Operation Panel and Feedback

6.1 Operation panel

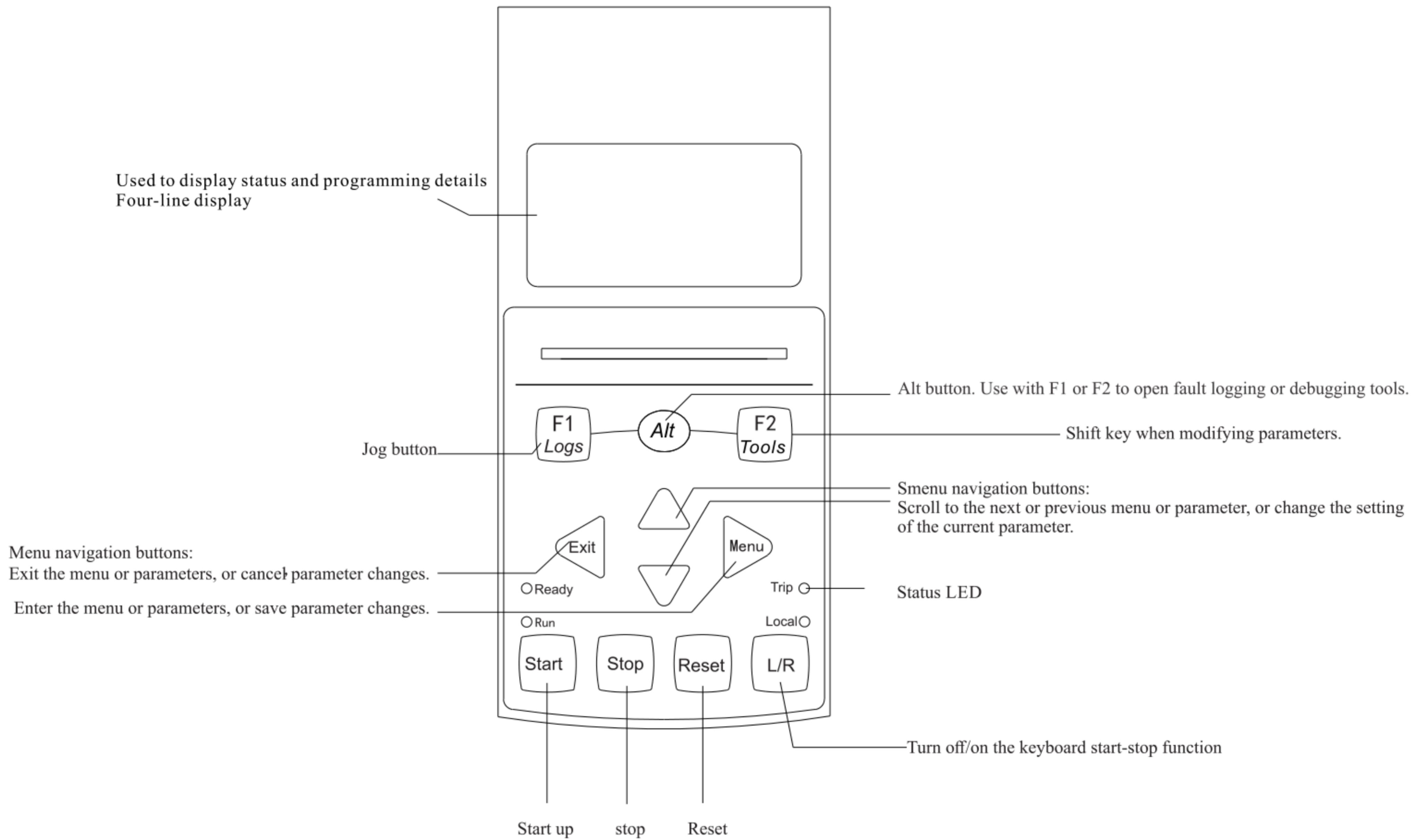

starter status LED

LED name	Chang Liang	Flash Sparkle
Ready	The motor stops and the starter is ready to start.	
Run	The motor is in the state of starting, running, soft stop and DC braking	
Trip	The starter has tripped.	The starter is in a warning state.
Local	The starter is in local control mode.	

- The local LED light only works for the keyboard control mode. The light on means that the panel can be started and stopped, and the light off means that the panel cannot be started or stopped.

6.2 Display

The operation panel will display various information about the status of the soft starter. Have a default display mode and a custom display mode. Default display

Default display

Custom display

Default display

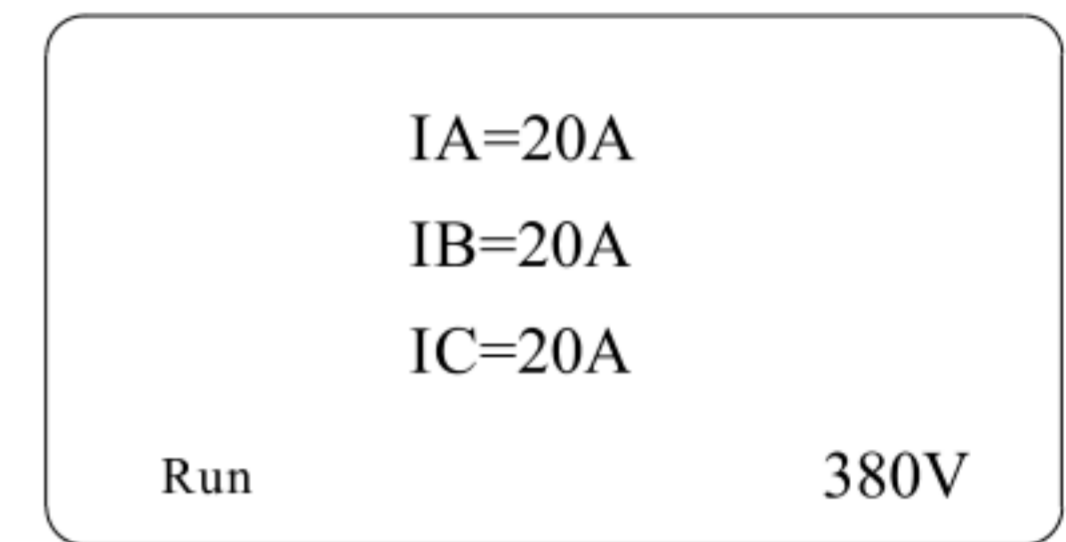
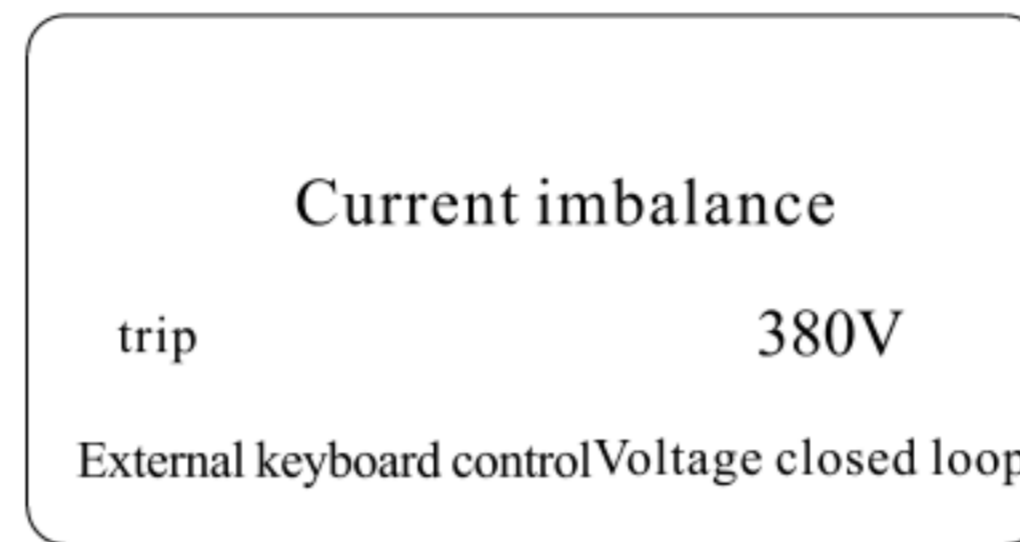
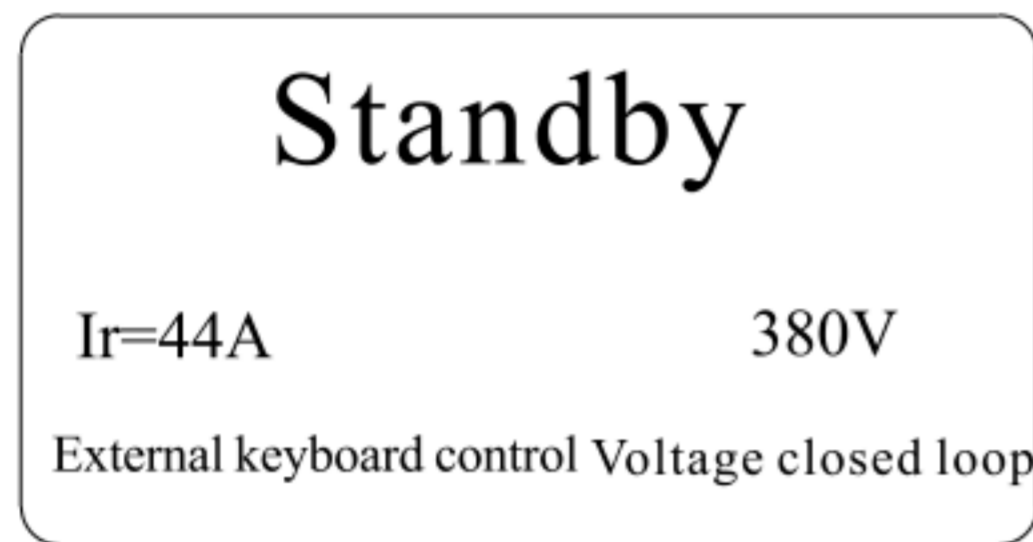

The default display cannot be changed, 4 lines display.

In the standby state, the first 2 lines display standby, the lower 2 lines display fixed parameters, the upper left corner is the soft start rated current, the lower left corner is the control mode, and the upper right corner is Input voltage, the lower right corner is the starting mode.

In the fault state, the first line does not display, the second line displays the cause of the fault, the bottom two lines display the fixed parameters, the upper left corner is the soft start state, and the lower left corner is the control mode.

The upper right corner is the input voltage, and the lower right corner is the starting mode.

In the running state, the first 3 lines display the operating currents of the three phases A, B, and C. The left side of the 4th line displays the soft start status, and the right side displays the input voltage.

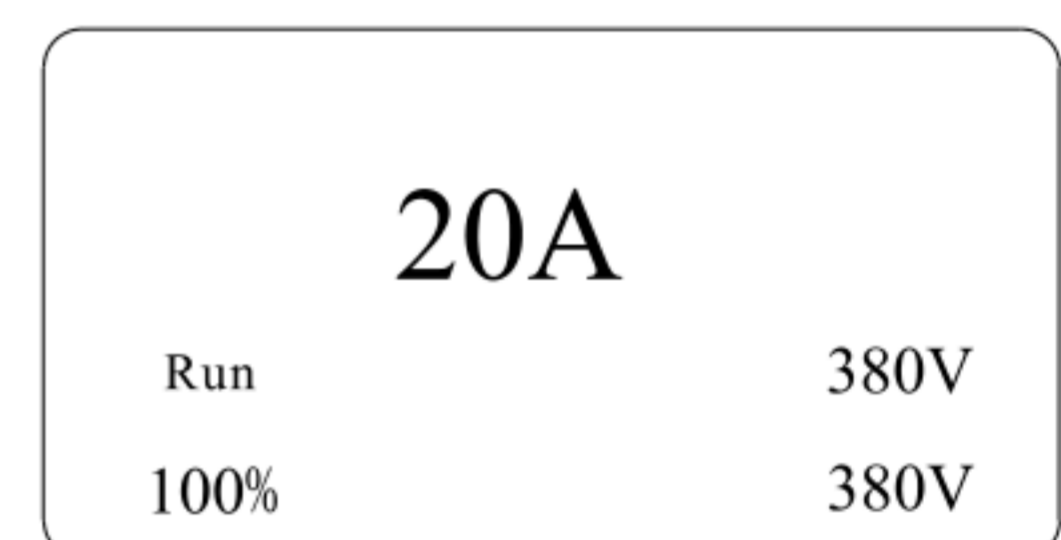
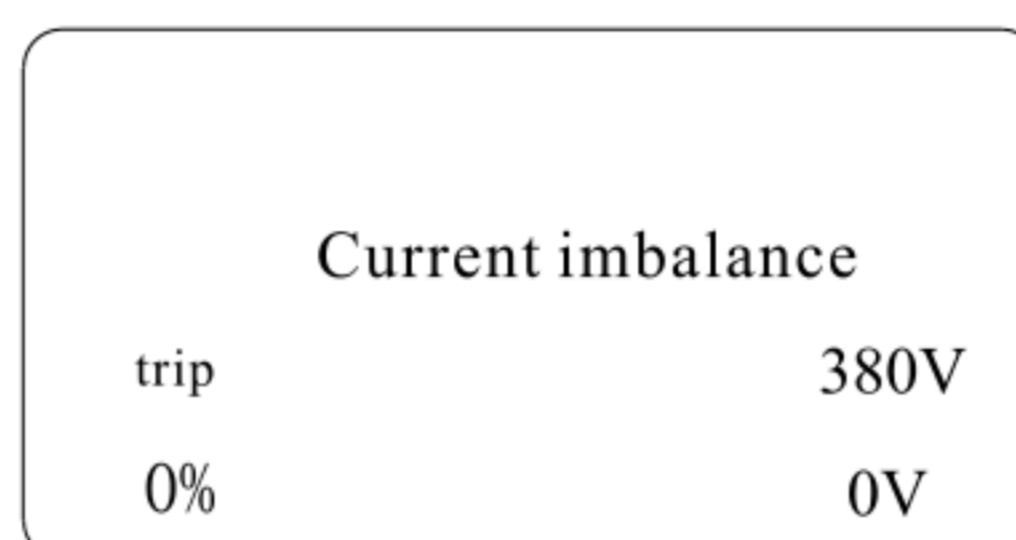

The custom display can be changed according to your needs, with 4 lines of display. The first 2 lines cannot be changed, and the last 2 lines can be modified (selected in parameters G02-G05). Optional letter

Information (0. Blank 1. Soft start state 2. Control mode 3. Start mode 4. Input voltage 5. Output voltage 6. Start percentage 7. Soft start temperature 8. Motor temperature 9. Start

Number of operations 10. Running time 11. Power frequency 12. Power phase sequence)

Chapter 7 Maintenance Tools

7.1 Test equipment installation

You can connect the soft starter to a small motor for testing. During this test, the soft starter control input and relay output protection settings can be tested.

This test mode is not suitable for testing soft start performance or soft stop performance.

7.2 Tools

The "Debug Menu" provides access to debugging and testing tools. Press ALT and then F2 to open "Tools".

There are three tools: restore factory settings, clear fault records and simulate running. After opening "tools", press F2 shift key to switch.

Follow the instructions to perform the corresponding operations.

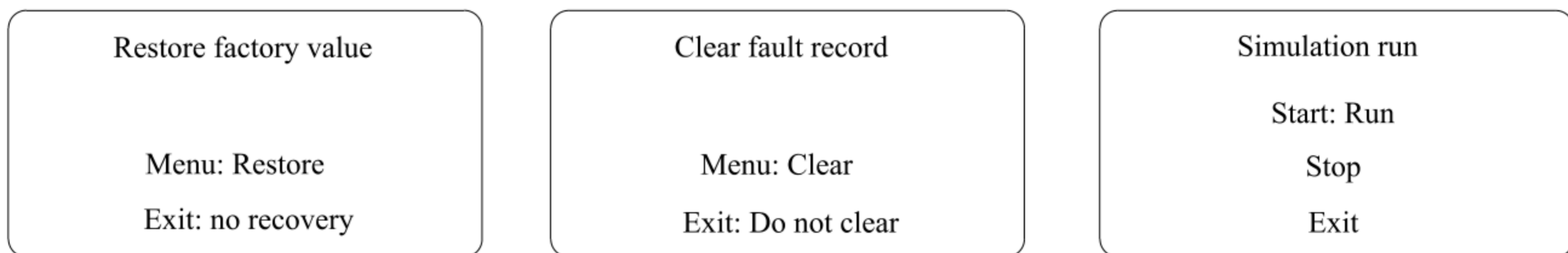

Simulation tool

The software simulation function allows you to test the soft starter's working condition and control circuit when the main circuit of the soft starter is not connected to the power supply voltage.

The simulation tool can be accessed through the debug menu. The simulation function can only be used when the soft starter is in the ready state, there is a control voltage, and the operation panel is active.

7.3 Fault record

The fault record can display the last 10 fault records, press ALT, then press F1 to call out, press ▲ or ▼ to switch and browse, press ◀ or ▶ Exit to the main interface.

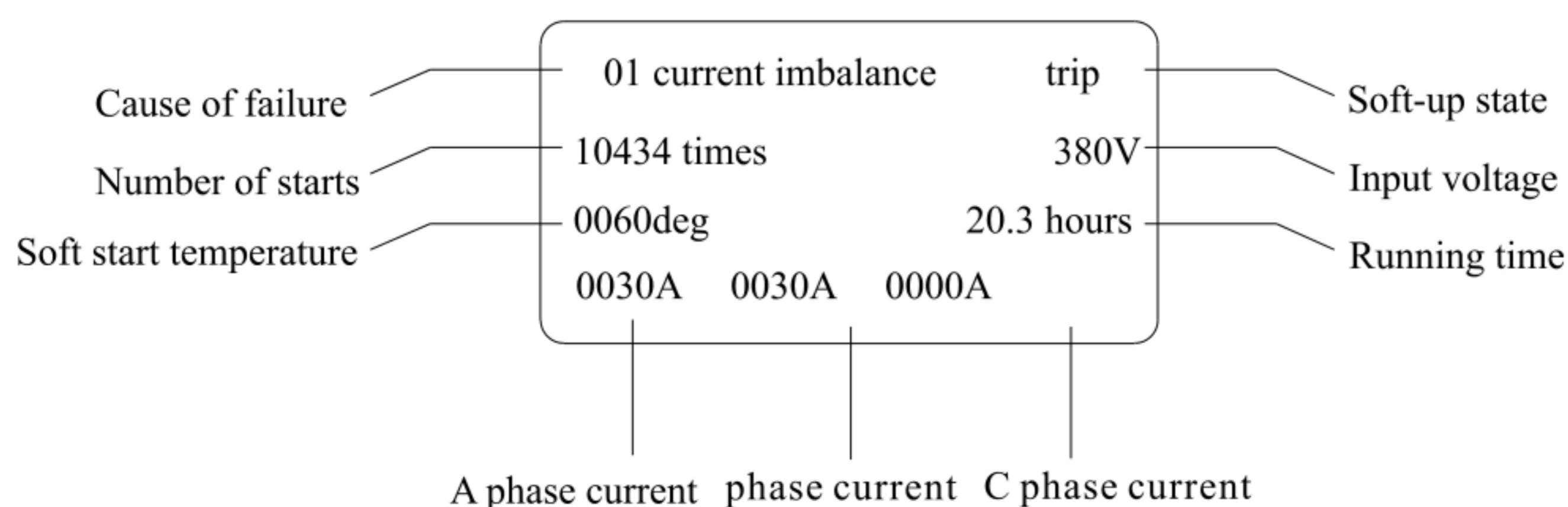

Chapter 8 Operation

8.1 Start, stop and reset commands

Eight methods can be used to control the soft starter:

- No start and stop
- Individual keyboard control
- External control alone control
- Keyboard + external control
- Separate communication control
- Keyboard + communication
- External control + communication
- Keyboard + external control + communication

The L/R (local/remote) button only works for the keyboard control mode. The light on means that the panel can be started and stopped, and the light off means that the panel cannot be started or stopped.

Control the motor with a soft starter

To soft start the motor, press the START button on the operation panel, or activate the "start remote input". The motor will start using the starting mode selected in parameter A02.

To soft stop the motor, press the STOP button on the operation panel, or activate "Stop Remote Input". The motor will stop according to the stop mode selected by parameter A16.

To reset the soft starter trip, press the RESET button on the operation panel, or activate the "Reset Remote Input".

8.2 Soft start method

The soft starter provides a variety of methods to control the starting of the motor. Each soft start method uses different main control parameters.

Soft start method	Controlled parameter	Affected performance parameters
Voltage start	Voltage	Percentage of starting voltage, starting time
Current limit start	Current	Starting voltage percentage, starting current limit percentage
Torque start	Torque	Maintain voltage, early acceleration time, sustain time, post acceleration time
Direct start	Relay	No

The best results can be achieved by selecting a soft start method that can directly control the most important application parameters. Usually a soft starter is used to limit the starting current of the motor, Or control load acceleration and/or deceleration. The soft starter can be set to voltage start or current limit start. Both voltage start and current limit start have open loop and closed loop. The closed loop start is used by default. Open loop mode can be used when some special field closed loop mode cannot be started.

Control	with
Motor starting current	Current limit start
Motor/load acceleration	Voltage start

Voltage start

Voltage ramp start is a traditional soft start form. When the motor starts, the output voltage of the soft starter rises rapidly to U_1 , and then the output voltage is set according to the setting

The starting parameters of the motor gradually increase, and the motor continues to accelerate steadily as the voltage rises, until the thyristor is fully turned on and the output voltage reaches U_e . Note: Voltage

The modes are divided into closed loop and open loop. The minimum value of U_1 in closed loop is 37%. When the percentage setting of A04 initial voltage is lower than 37%, it will start according to $U_1=37\%$. When A04 is set

When set to 37% or more, it will start according to the set value. When the loop is open, it starts completely according to the setting of A04.

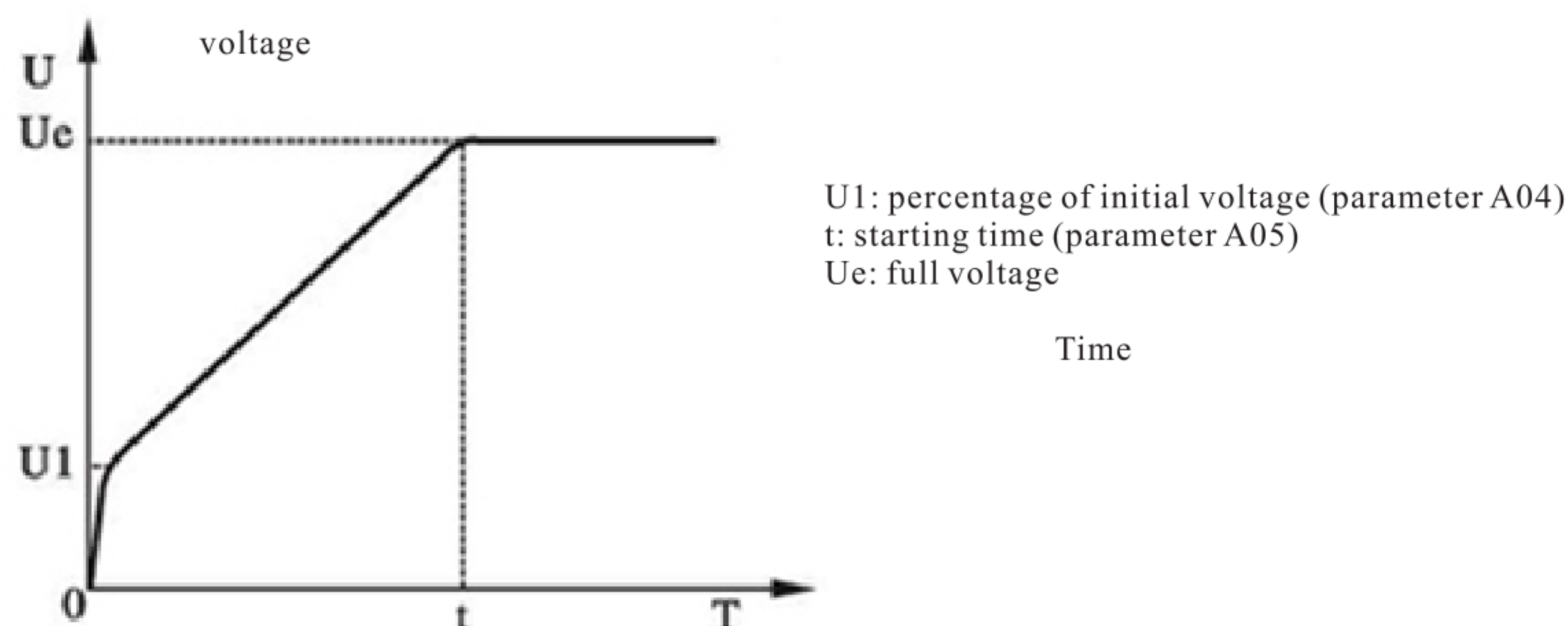

Current limit start

Current-limiting starting is a traditional form of soft-starting. When the motor starts, the output voltage increases rapidly until the motor current reaches the set current limit value I_1 .

Keep the motor current not greater than this value, and then as the output voltage gradually increases, the motor gradually accelerates, when the motor reaches the rated speed, the bypass contactor

Pull-in, the output current quickly drops to the motor rated current I_e or below, and the starting process is completed. When the motor load is lighter or the set current limit value is larger,

It is normal when the maximum current at starting may not reach the set current limit value.

Current-limiting starting mode is generally used in occasions that have strict requirements on starting current. Note: The current limiting mode is not limited by time, as long as the motor runs at full speed

It is considered that the start is completed. The current limiting mode is divided into closed loop and open loop. The minimum value of U_1 in closed loop is 37%. When the percentage of A04 initial voltage is set lower than 37%, follow

$U_1=37\%$ start, when A04 is set to be greater than or equal to 37%, start according to the set value. When the loop is open, it starts completely according to the setting of A04.

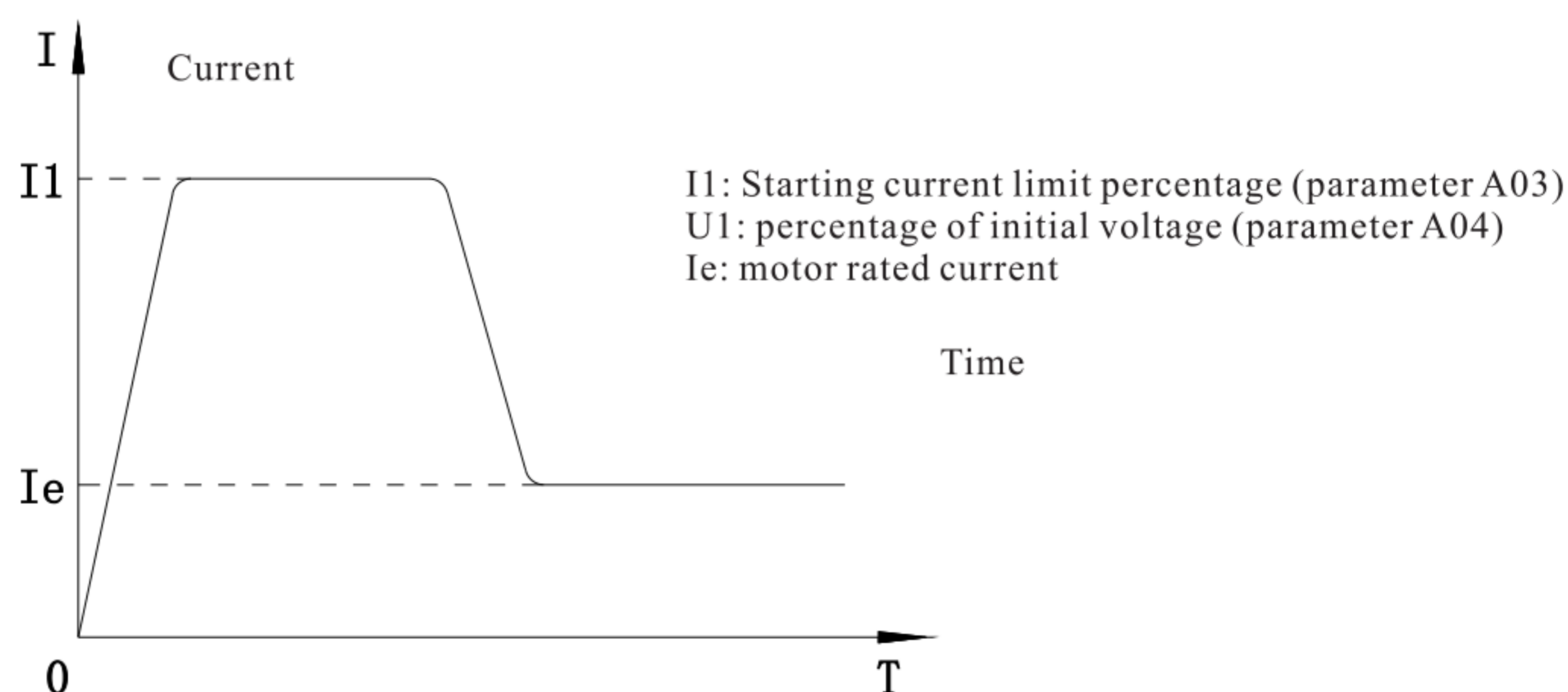

Torque start

Torque starting is a starting mode to deal with unstable power supply, especially when the power supply is a generator. When the motor starts, the output voltage is in accordance with the early acceleration. Accelerate to the maintenance voltage during the time, and maintain the maintenance voltage according to the maintenance time, and finally accelerate to the full pressure according to the post-acceleration time, the starting process ends, and the transfer Line status.

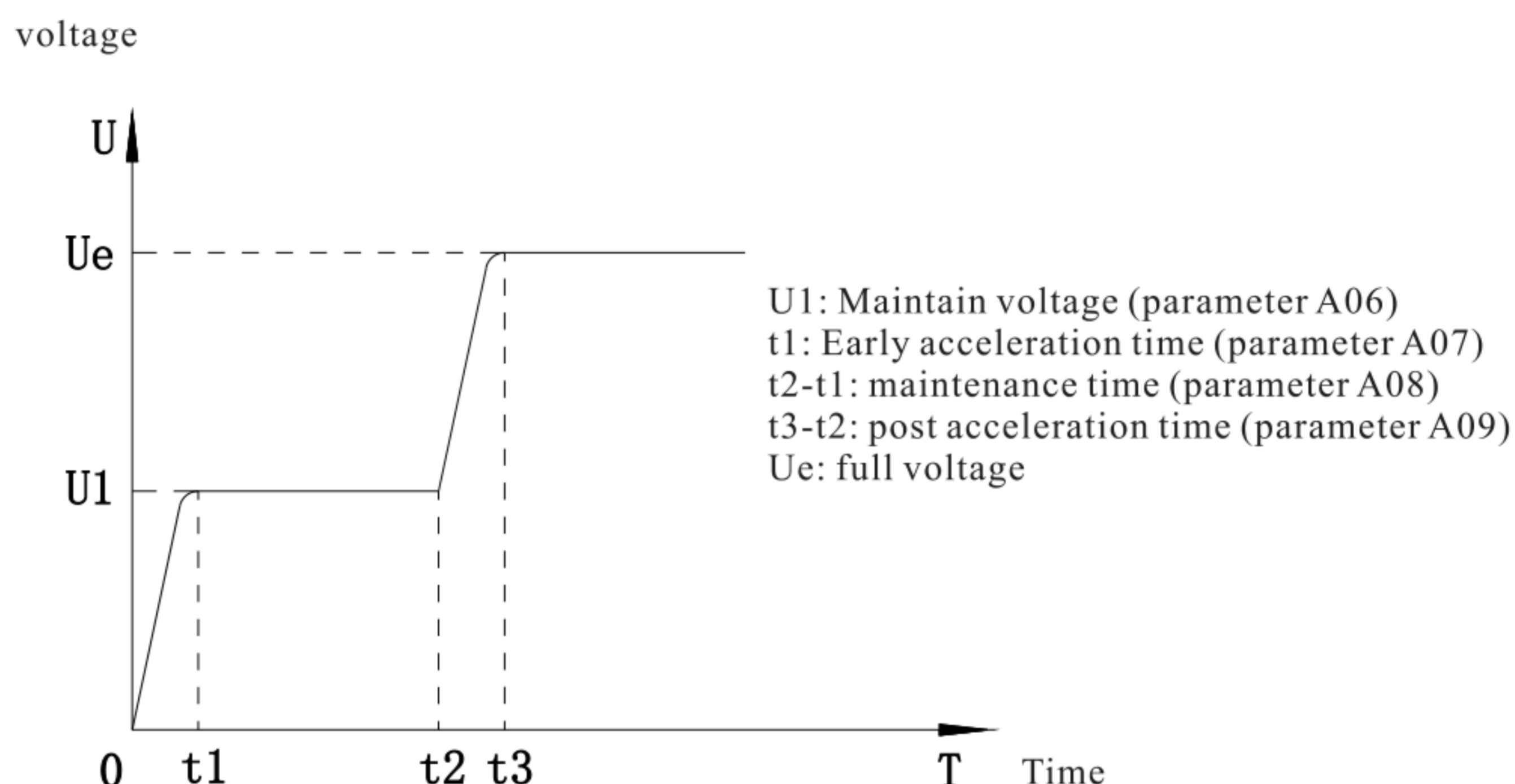

Kick start

Kick start is to provide additional torque for a period of time at the beginning of starting. In some heavy load situations, the electric motor cannot be started due to the influence of mechanical static friction.

When the machine is running, this starting mode can be selected. When starting, first apply a higher fixed voltage to the motor for a limited period of time to overcome the electrical

The static friction of the machine load causes the motor to rotate, and then starts in the manner of current limiting or voltage ramp.

Before using this mode, you should first start in non-sudden mode

For the motor, if the motor cannot rotate due to too much static friction, choose this mode; otherwise, this mode should be avoided to start, in order to reduce unnecessary large electricity.

Flow shock. Note: When the kick time is 0, it means that there is no kick effect.

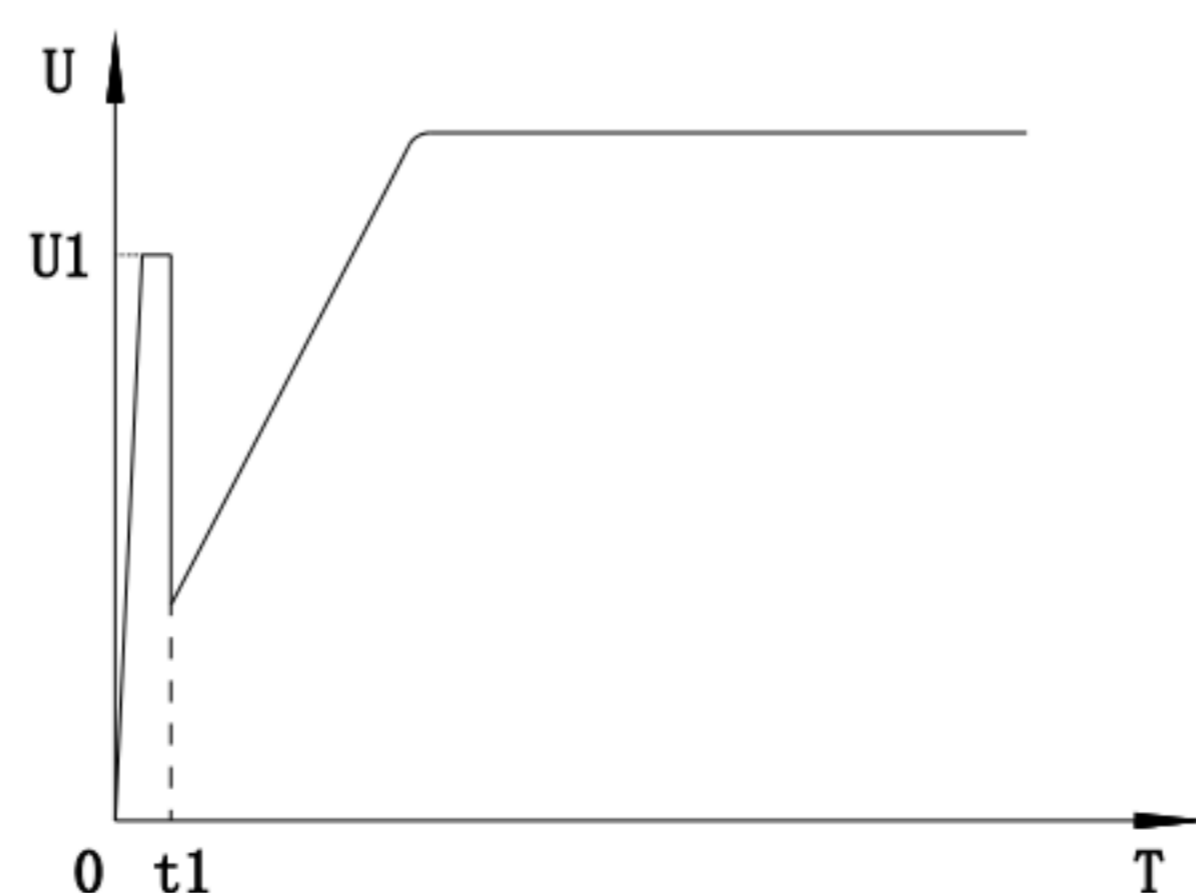
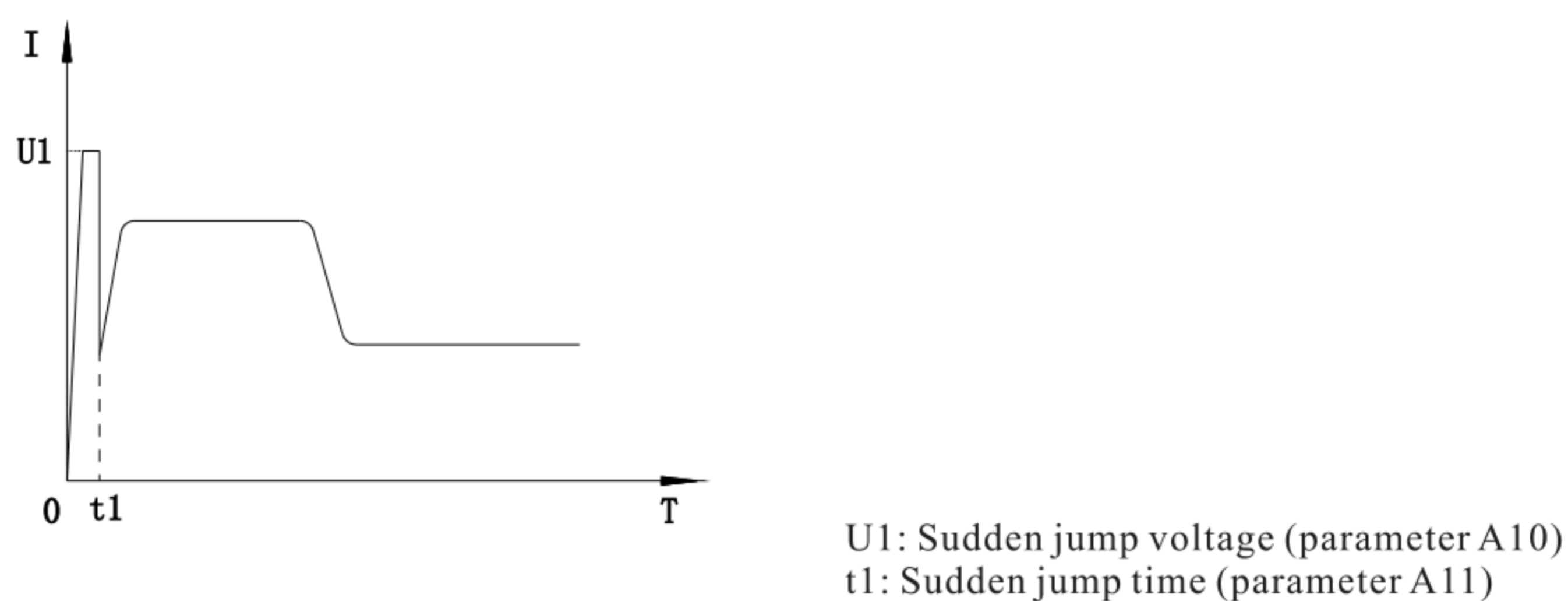

8.3 Stop method

The soft starter provides a variety of methods to control the motor to stop.

Stop method	Performance result
Free parking	Natural load stop
Soft parking	Extend stop time
DC brake parking	Shorten stop time

Free parking

Free stop allows the motor to decelerate at natural speed without being controlled by the soft starter. The time required to stop depends on the type of load.

Soft parking

The soft stop gradually reduces the motor voltage within the specified time. After the end of the stop ramp, the load may continue to run. Voltage soft stop can be used to request delay Long stop time applications, or applications that need to avoid transients in the power supply of the generator set.

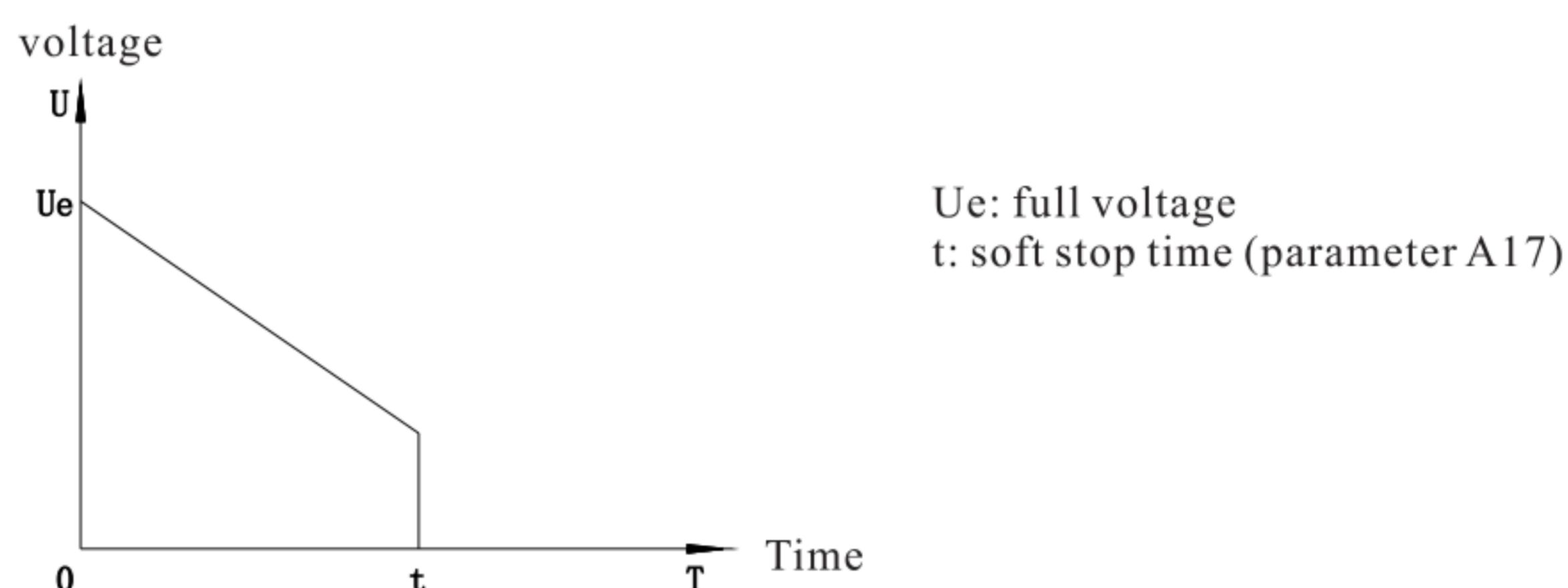

DC brake parking

Braking can shorten the stopping time of the motor.

During the braking process, the motor can hear louder noises. This is a normal motor braking phenomenon. After selecting the brake, the soft starter will use DC

The injection method decelerates the motor, and the braking force is set according to the parameter A18 DC braking force. There is no need to use a DC brake contactor. Control all three phases to make electricity

The braking current and corresponding heat generation in the machine are evenly distributed.

Note:



If the braking torque is set too large, the motor will stop before the end of the braking time, and the motor will generate too much heat, which may cause damage to the motor.

The braking torque must be carefully configured to ensure the safe operation of the starter and motor. Setting the braking torque too large will cause the motor to stop,

Peak current appears when starting the motor directly. Ensure that the fuses installed in the motor branch circuit are correctly selected.



Note:

The braking operation makes the motor heat faster than the speed calculated by the motor thermal protection model.

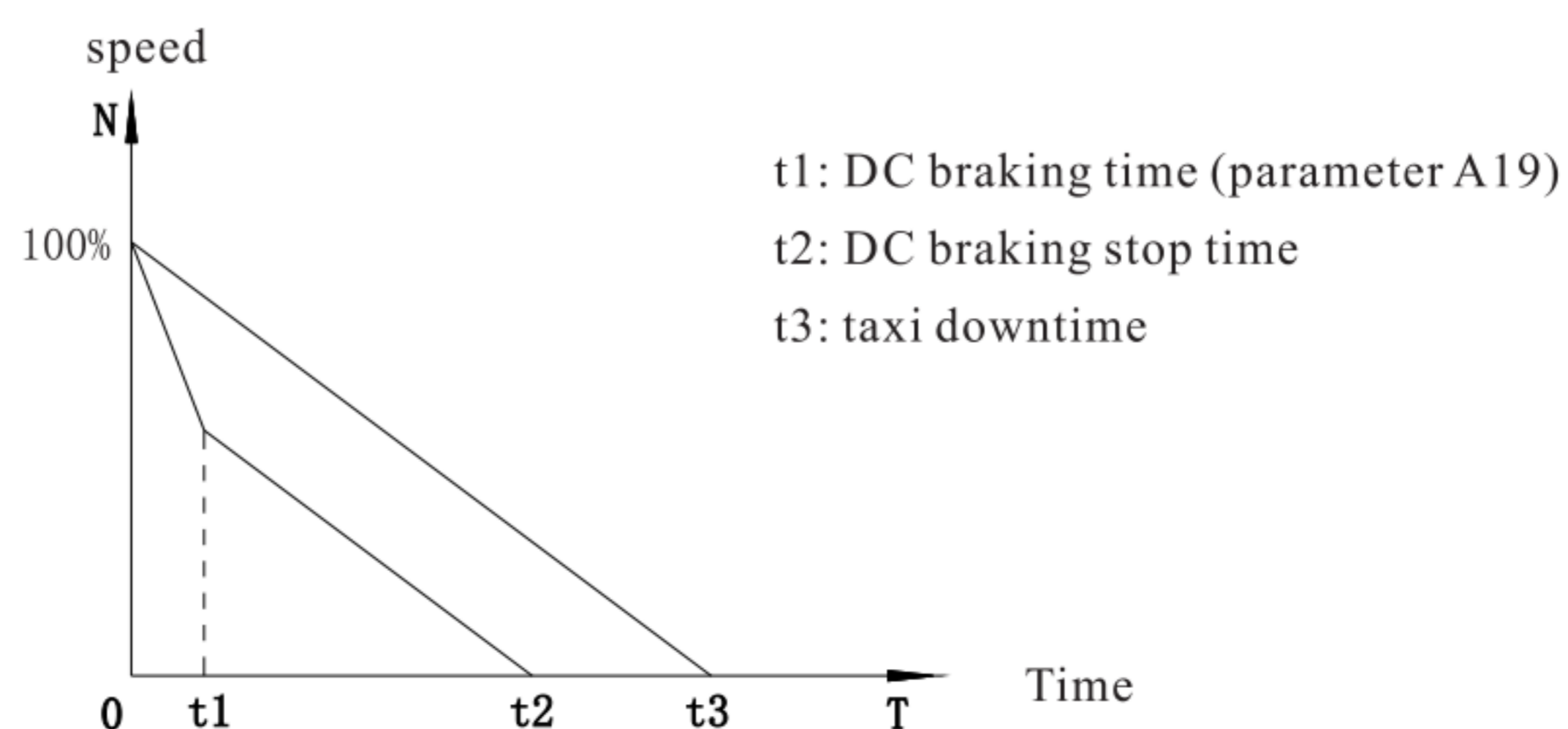

8.4 Jog operation

Jog allows the motor to decelerate to run in order to adjust the load or assist in maintenance. The motor can be jog forward or reverse.



Note:

Low-speed operation reduces the cooling effect of the motor, which is not suitable for use in continuous working mode.

The jog operation makes the motor heating speed faster than the speed calculated by the motor thermal protection model.

The jog command is the F1 button, long press to jog operation, or short-circuit JOG and com on the terminal can also realize jog operation, jog operation

The voltage is related to the parameter A12 jog maintenance voltage.

Chapter 9 Programming Menu

The programming menu can be accessed at any time, including when the soft starter is running. Any changes made to the starting curve take effect immediately.

The programming menu has seven submenus:

A basic parameters B protection parameters C protection level D calibration function E additional functions F status information G display parameters

9.1 Programming menu

You can use the programming menu to view and change the programmable parameters, which control the working mode of the soft starter.

While viewing the monitoring screen, press the menu button to open the programming menu.

Browse the "Programming Menu":

- Press ▲ or ▼ to scroll through the parameter group.
- Press the ► Menu button to open the submenu.
- Press the ► Menu button to view the parameters in the parameter group.
- Press the ◀ EXIT button to return to the previous menu.
- To close the "Programming Menu", you need to press ◀EXIT several times.

Change parameter value:

- Scroll to the corresponding parameter in the "programming menu", and then press ►Menu to enter the editing mode.
- Use F2 to move, and use the ▲ and ▼ buttons to change the parameter settings. Press the ▲ or ▼ button once to increase or decrease the parameter value by one unit.
- To save the changes, press ► Menu (Store). The settings on the display will be saved and the control panel will return to the parameter list.
- To cancel the changes, press ◀ EXIT. The operation panel will ask whether to confirm to cancel the changes, and then return to the parameter table without saving the changes.

9.2 Parameter write protection

The programming menu can be locked to prevent users from modifying parameter settings. You can use parameter E15 to set password write protection. Lock programming menu:

1. Open the programming menu.
2. Turn on the E additional function.
3. Select E15 parameter setting password
4. Enter the access code.

If the user wants to enter the programming menu after setting the password, he must enter the correct password, otherwise he will return to the main interface.

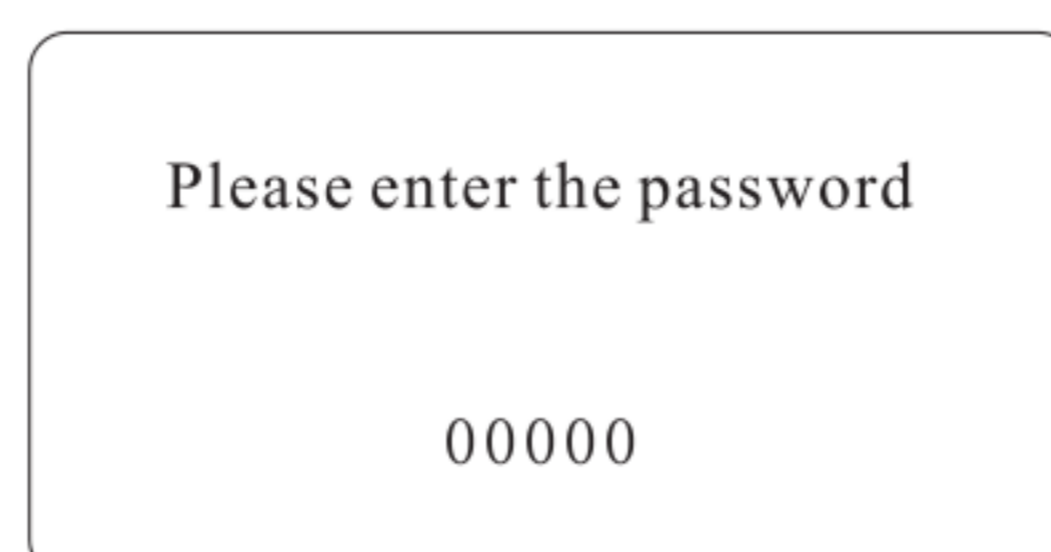

9.3 Basic parameters

The basic parameters provide the start and stop settings of the soft starter, and the user can configure the soft starter according to their application requirements.

Main item	dependent	Parameter range	Default value	Remarks	Attribute
A Base This Participate Number	A00. Application selection	0: general load 1: Fan 2: Water pump 3: Crusher 4: Ball mill	0: general load		⊙
	A01. Control method	0: Prohibit start and stop 1: The keyboard is individually controlled 2: External control alone control 3: Keyboard + external control 4: Communication is controlled separately 5: keyboard + communication 6: External control + communication 7: keyboard+external control+communication	3: Keyboard + external control		⊙
	A02. Starting method	0: Voltage closed loop start 1: Voltage open loop start 2: Current closed loop start 3: Current open loop start 4: Torque start 5: Direct start	0: Voltage closed loop start		⊙
	A03. Starting current limit percentage	50%~600%	300%		⊙
	A04. Starting voltage percentage	20%~80%	35%		⊙
	A05. Starting time	1s~120s	15s		⊙
	A06. Maintain voltage	60%~85%	65%		⊙
	A07. Early acceleration time	1s~10s	5s		⊙
	A08. Maintenance time	1s~120s	10s		⊙
	A09. After acceleration time	1s~10s	3s		⊙
	A10. Kick voltage	10%~95%	80%		⊙
	A11. Sudden jump time	0ms~2000ms 0 means no kick	0ms		⊙
	A12. Jog voltage	10%~80%	40%		⊙
	A13. Second start time	0s~120s 0 means that the second start is prohibited	0s		⊙
	A14. Second start stop time	0s~120s 0 means do not stop directly changing the current limit value	0s		⊙
	A15. Secondary starting current limit multiple	50%~600%			⊙
	A16. Stop modeng current limit multiple	0: Free parking 1: Soft parking 2: DC braking to stop	0: Free parking		⊙
	A17. Soft stop time	1s~120s	5s		⊙
	A18. DC braking force	10%~100%	40%		⊙
	A19. DC braking time	2s~120s	10s		⊙
A20. Soft starter type	0: Online 1: Built-in bypass type 2: External bypass type	1: Built-in bypass type		⊙	

9.4 Protection parameters

The protection parameters provide some protection values and protection times for the soft starter. Users can configure the soft starter according to their application requirements.

Main item	Dependent	Parameter range	Default value	Remarks	Attribute
B Protect Protect Participate Number	B00. Starting overload level	1~30	10		⊙
	B01. Running overload level	1~30	10		⊙
	B02. Starting overcurrent multiple	50%-600%	500%		⊙
	B03. Starting overcurrent protection time	0s-120s	5s		⊙
	B04. Running overcurrent multiple	50%-600%	200%		⊙
	B05. Running overcurrent protection time	0s-6000s	5s		⊙
	B06. Overvoltage protection multiple	100%~140%	120%		⊙
	B07. Overvoltage protection time	0s~120s	5s		⊙
	B08. Undervoltage protection multiple	60%-100%	80%		⊙
	B09. Undervoltage protection time	0s~120s	5s		⊙
	B10. Three-phase unbalance	20%~100%	40%		⊙
	B11. Three-phase unbalance time	0s~120s	3s		⊙
	B12. Starting overtime	1s~150s	60s		⊙
	B13. Jog timeout	1s~150s	60s		⊙
	B14. Underload protection multiple	10%~100%	50%		⊙
	B15. Underload protection time	1s~120s	10s		⊙
	B16. Phase sequence selection	0: Any phase sequence 1: Positive phase sequence 2: Reverse order	0: Any phase sequence		⊙
	B17. Frequency protection upper limit	55Hz~75Hz	75Hz		⊙
	B18. Lower limit of frequency protection	35Hz~55Hz	35Hz		⊙
B19. Frequency protection time	0~120s	2s		⊙	

9.5 Protection level

The protection level provides protection of the soft starter whether it will alarm or stop, and the user can configure the soft starter according to their application requirements.

Main item	Dependent	Parameter range	Default value	Remarks	Attribute
C Protect Protect Wait Level	0C00. Starting overload	0: Trip to stop 1: Alarm and no shutdown 2: Ignore	0:0: Trip to stop		⊙
	C01. Running overload		0: Trip to stop		⊙
	C02. Starting overcurrent		2: Ignore		⊙
	C03. Running over current		2: Ignore		⊙
	C04. Overvoltage		0: Trip to stop		⊙
	C05. Undervoltage		0: Trip to stop		⊙
	C06. Three-phase unbalance		0: Trip to stop		⊙
	C07. Start timeout		2: Ignore		⊙
	C08. Jog timeout		2: Ignore		⊙
	C09. Underload		2: Ignore		⊙
	C10. Soft start overheating		0: Trip to stop		⊙
	C11. Motor overheated		2: Ignore		⊙
	C12. Short circuit between phases		0: Trip to stop		⊙
	C13. Ground fault		0: Trip to stop		⊙
	C14. Phase sequence protection		2: Ignore		⊙
	C15. Thyristor breakdown		0: Trip to stop		⊙
	C16. External fault		0: Trip to stop		⊙
C17. Frequency protection	0: Trip to stop		⊙		

9.6 Calibration function

The guarantee calibration function provides the calibration of the voltage, current, and analog output of the soft starter. Users can configure the soft starter according to their application requirements.

Main item	Dependent	Parameter range	Default value	Remarks	Attribute
D School Quasi Work Can	D00.A phase current calibration value	10%~1000%	100%		○
	D01.B phase current calibration value	10%~1000%	100%		○
	D02.C phase current calibration value	10%~1000%	100%		○
	D03. Input voltage calibration value	10%~1000%	100%		○
	D04. Output voltage calibration value	10%~1000%	100%		◎
	D05.4-20mA lower limit calibration	0%~150.0%	20.0%		◎
	D06.4-20mA upper limit calibration	0%~150.0%	100.0%		◎

9.7 Additional functions

The additional function provides the modification of some additional parameters, and the user can configure the soft starter according to their application requirements.

Main item	Dependent	Parameter range	Default value	Remarks	Attribute	
E Additional features	E00. Programmable Relay 1	Dfunction: 0: No action 1: Power-on action 2: Soft start action 3: Bypass action 4: Soft stop action 5: Action during jog 6: Action at runtime 7: Standby action 8: Fault action 9: Thyristor breakdown action 10: Action 1 when the current is greater than the reached value 11: The current is greater than the reached value action 2 12: Action 1 when the current is less than the reached value 13: The current is less than the reached value action 2 Delay: 0-600s	8: Fault action		◎	
	E01. Programmable output delay 1		0s		◎	
	E02. Programmable Relay 2		6: Action at runtime		◎	
	E03. Programmable output delay 2		0s		◎	
	E04. Current reaches 1		1%~600%	100%		◎
	E05. Current arrival hysteresis 1		1%~100%	20%		◎
	E06. Current reaches 2		1%~600%	70%		◎
	E07. Current arrival hysteresis 2		1%~100%	20%		◎
	E08.4~20mA function selection		0: output current 1: Starting percentage 2: Soft starter temperature 3: Motor temperature	0: output current		◎
	E09.4-20mA upper limit current		50%~500%	200%		◎
	E10. External control start-stop mode		0: Level mode 1: Pulse mode	0: Level mode		◎
	E11. Motor connection method		0: line 1: Inner triangle	0: line		◎
	E12. Communication protocol selection		0: no communication 1: ModbusRTU	1: ModbusRTU		◎
	E13. Mailing address		1-127	1		◎
	Me14. Communication baud rate		0:2400 1:4800 2:9600 3:19200	2:9600		◎
	E15. Reserved					◎
E16. Parameter setting password	00000~65535 00000 means no password	00000				

9.8 Status information

Status information can view the current running status and some parameters of the soft starter in real time.

Main item	Dependent	Parameter range	Default value	Remarks	Attribute
F State State Letter Interest	F00. Soft start rated current				●
	F01. Soft start rated voltage				●
	F02. Motor rated current				◎
	F03. Average current				●
	F04. Input voltage				●
	F05. Output voltage				●
	F06. A phase current value				●
	F07. B phase current value				●
	F08. C phase current value				●
	F09. Start complete percentage				●
	F10. Three-phase current unbalance				●
	F11. Apparent power				●
	F12. Power frequency				●
	F13. Power phase sequence	Positive phase sequence/reverse phase sequence			●
	F14. Radiator temperature				●
	F15. Motor temperature				●
	F16. Soft start times	0~65535			●
	F17. Cumulative running time	0 minutes to 10000 days			●
	F18. Current running time	0 minutes to 10000 days			●
	F19. Real time	xxxx year xx month xx day xx hours xx minutes xx seconds			●
F20. Main control software version				●	

9.9 Display parameters

The display parameters provide some screen display options, and users can configure the soft starter according to their application requirements.

Main item	Dependent	Parameter range	Default value	Remarks	Attribute
G Show Show Participate Number	G00. Standby display mode G	0: default 1: Custom	0: default 0		○
	01. Operation display mode	0: default 1: Custom	0: default 0		○
	G02. The upper left corner of the screen	0: blank 1: Soft start state 2: Control method 3: Starting method 4: Input voltage 5: Output voltage 6: Starting percentage 7: radiator temperature 8: Motor temperature 9: Number of motor starts 10: current running time 11: Power frequency 12: Power phase sequence	1: Soft starter status		○
	G03. The upper right corner of the screen		4: Input voltage		○
	G04. The lower left corner of the screen		3: Starting method		○
	G05. The bottom right corner of the screen		6: Starting percentage		○
	G06. Operation language selection	0: English 1: Chinese	1: Chinese		○
	G07. Screen saver time	0s~1800s 0 means off	120		○
	G08. Keyboard software version				●

Note: ○: means that the parameter value can be modified when the soft starter is in stop and running state. ○: Indicates that the parameter value cannot be modified when the soft starter is in the running state.
●: Indicates that the parameter value is a read-only parameter and cannot be modified.

9.10 Parameter description

A. Basic parameters

A00. Application selection

Application selection gives examples of several common load types to facilitate quick configuration of the soft starter. Default value: 0. Universal load.

Application	parameter	Parameter value
0. General load	0A02 starting method	0. Voltage closed loop start
	A04 initial voltage percentage	35%
	A05 start time	30S
1. Fan	A02 starting method	2. Current limit closed loop start
	A03 starting current limit percentage	300%
	A04 initial voltage percentage	40%
2. Water pump	A02 starting method	2. Current limit closed loop start
	A03 starting current limit percentage	300%
	A04 initial voltage percentage	40%
3. Crusher	A02 starting method	4. Torque start
	A06 sustain voltage	65%
	A07 early acceleration time	3S
	A08 maintenance time	60S
	Acceleration time after A09	3S
4. Ball mill	A02 starting method	4. Torque start
	A06 sustain voltage	65%
	A07 early acceleration time	3S
	A08 maintenance time	60S
	Acceleration time after A09	3S

A01. Control method

Range: 0-7

Default value: 3

Description: Set the control mode used to select the soft starter.

The following form is attached, √ means start and stop can be started, × means start and stop is not allowed

Numerical value	0	1	2	3	4	5	6	7
Keyboard	×	√	×	√	×	√	×	√
Terminal	×	×	√	√	×	×	√	√
Communication	×	×	×	×	√	√	√	√

A02. Starting method

Options: 0: Voltage closed loop start (default) 1: Voltage open loop start 2: Current closed loop start
3: Current open loop start 4: Torque start 5: Direct start

Description: Select soft start mode.

A03. Starting current limit percentage

Range: 50%-600% rated current Default value: 300%

Description: Set the maximum value of the starting current of the soft start during current-limiting starting, which is the percentage of the rated current of the motor.

A04. Starting voltage percentage

Options: 20%-80%

Description: Set the initial starting voltage value for voltage start and current limit start. The minimum initial voltage in closed-loop mode is 37%, if it is lower than 37%, it will start at 37%, which is greater than or equal to 37% starts according to the set value.

A05. Starting time

Range: 1S-120S Default value: 15S
Description: Set the total starting time of soft start during voltage start.

A06. Maintain voltage

Range: 60%-85% Default value: 65%
Description: Set the voltage maintenance value during torque start.

A07. Early acceleration time

Range: 1S-10S Default value: 5S
Description: Set the acceleration time of the first stage of acceleration during torque start, after the acceleration is completed, the output voltage will remain at the maintenance voltage.

A08. Maintenance time

DeRange: 1S-120S Default value: 10S
Description: Set the duration of the maintenance voltage during torque starting, during which the output voltage will remain at the maintenance voltage.

A09. After acceleration time

Range: 1S-10S Default value: 3S
Description: Set the acceleration time of the second stage of acceleration during torque start, during this period of time from the maintenance voltage to the full voltage output.

A10. Kick voltage

Range: 10%-95% Default value: 80%
Description: Set the voltage amplitude of kick start. Kick start makes the device increase the torque. Before using this function, make sure that the motor and load and the coupling can withstand additional torque.

A11. Sudden jump time

Range: 0mS-2000mS Default value: 0mS
Description: Set the duration of kick start, setting 0 means kick start is prohibited.

A12. Jog voltage

Range: 10%-80% Default value: 40%
Description: Set the output voltage of the motor during jog operation.

A13. Second start time

Range: 1S-120S Default value: 0S
Note: When setting the second start, after starting according to the set time, press the A15 setting value to convert the current limit multiple to start, set to 0 to indicate prohibition only the second start.

A14. Second start stop time

Range: 1S-120S Default value: 0S
Note: When setting the second start, the interval time from the end of the first start to the start of the second start, set to 0 means no stop, straight Press the A15 setting value to convert the current limit multiple to start.

A15. Secondary starting current limit multiple

Range: 50%-600% of rated current Default value: 400%

Description: Set the maximum value of the second starting current of the second starting, which is the percentage of the rated current of the motor.

A16. Stop mode

Roptions: 0: Free stop (default) 1: Soft stop 2: DC brake stop

Description: Select the stop method.

A17. Soft stop time

Range: 1S-60S Default value: 5S

Description: Set the imaginary time when the timing voltage ramp is used to soft stop the motor. After the soft stop, the motor will automatically slide until it stops.

A18. DC braking force

Range: 10%-150% Default value: 40%

Note: Set the braking force when using DC braking to stop. After DC braking, the motor will automatically slide until it stops.

A19. DC braking time

Range: 2S-120S Default value: 10S

Note: Set the duration of DC power supply when using DC braking to stop.

A20. Soft starter type

Options: 0: Online type 1: Built-in bypass type (default) 2: External bypass type

Description: Select the working type of the soft starter.

B. Protection parameters

B00. Starting overload level

Range: 1-30 Default value: 10

Note: The starting overload protection adopts inverse time limit control. Refer to the motor overload protection characteristic table or B02 and B03 parameters for the protection time corresponding to different levels. It is protected by the first arrival time.

B01. Running overload level

Range: 1-30 Default value: 10

Note: The running overload protection adopts inverse time limit control, and the protection time corresponding to different levels refers to the motor overload protection characteristic table or parameters B04 and B05. It is protected by the first arrival time.

B02. Starting overcurrent multiple

Range: 50%-600% rated current Default value: 500%

Description: Set the instantaneous overcurrent protection trip point of soft start during starting, which is the percentage of the rated current of the motor.

B03. Starting overcurrent protection time

Range: 0S-120S

Default value: 5S

Description: Set to reduce the response speed of soft start to start overcurrent to avoid tripping due to instantaneous fluctuations.

B04. Running overcurrent multiple

Range: 50%-600% of rated current Default value: 200%

Description: Set the operating overcurrent protection trip point of the soft start during operation, which is the percentage of the rated current of the motor.

B05. Running overcurrent protection time

Range: 0S-6000S

Default value: 5S

Description: Set to reduce the response speed of soft start to running overcurrent to avoid tripping due to instantaneous fluctuations.

B06. Overvoltage protection multiple

Range: 100%-140%

Default value: 120%

Explanation: Set the overvoltage protection trip value of soft start, if it exceeds the set value, it will protect.

B07. Overvoltage protection time

Range: 0S-120S

Default value: 5S

Description: Set to reduce the response speed of soft start to overvoltage to avoid tripping due to instantaneous fluctuations.

B08. Undervoltage protection multiple

Brange: 0S-120S

Default value: 5S

Description: Set to reduce the response speed of soft start to overvoltage to avoid tripping due to instantaneous fluctuations.

B09. Undervoltage protection time

Range: 0S-120S

Default value: 5S

Description: Set to reduce the response speed of soft start to undervoltage to avoid tripping due to instantaneous fluctuations.

B10. Three-phase unbalance

Range: 20%-100%

Default value: 40%

Explanation: Set the trip value of the three-phase unbalanced protection for soft start, and the phase-to-phase difference is greater than the set value for protection.

B11. Three-phase unbalance time

Range: 1S-600S

Default value: 3S

Description: Set to reduce the response speed of soft start to three-phase unbalance to avoid tripping due to instantaneous fluctuations.

B12. Starting overtime

Range: 1S-150S

Default value: 60S

Note: Set the protection for too long starting time, and it will be protected if it exceeds the set value before running.

B13. Jog timeout

Range: 1S-150S

Default value: 60S

Note: Set the jog time too long protection, and the jog running time exceeds the set value to protect.

B14. Underload protection multiple

Range: 10%-100%

Default value: 50%

Description: Set the trip point of the undercurrent protection for soft start during operation, which is a percentage of the rated current of the motor.

B15. Underload protection time

Range: 1S-120S

Default value: 10S

Description: Set to reduce the response speed of soft start to undercurrent to avoid tripping due to instantaneous fluctuations.

B16. Phase sequence selection

Options: 0: Any phase sequence (default) 1: Positive phase sequence 2: Reverse phase sequence

Description: Select which phase sequence the soft starter allows when starting. During the pre-start check, the starter checks its input terminals. If the actual phase sequence does not match the selected option, it will trip.

B17. Frequency protection upper limit

Range: 55Hz-75Hz

Default value: 75Hz

Description: Set the upper limit of the allowable frequency change for soft start.

B18. Frequency protection lower limit

Range: 35Hz-55Hz

Default value: 35Hz

Description: Set the lower limit of the allowable frequency change for soft start.

B19. Frequency protection time

Range: 0S-120S

Default value: 2S

Description: Set to reduce the response speed of soft start to frequency changes to avoid tripping due to instantaneous fluctuations.

Note: If the motor runs outside the specified frequency range for a long time, it may cause damage to the motor and permanent failure.

C. Protection level

These parameters define how the soft starter responds to different protection events. The soft starter can trip, issue a warning or ignore different Protection event. Write all protection events into the fault record.



Notice:

Cancelling the protection mechanism may endanger the safety of the starter and motor, and should only be used in an emergency.

Options: 0: Trip and stop 1: Alarm and no shutdown 2: Ignore

Description: Select the response of the soft starter to each protection.

Options:	C00. Starting overload	Default value: Trip to stop
	C01. Running overload	Default value: Trip to stop
	C02. Starting over current	Default value: Ignore
	C03. Running over current	Default value: Ignore
	C04. Overvoltage protection	Default value: trip and stop
	C05. Undervoltage protection	Default value: Trip to stop
	C06. Three-phase unbalance	Default value: Trip to stop
	C07. Start timeout	Default value: Ignore
	C08. Jog timeout	Default value: Ignore
	C09. Underload	Default value: Ignore
	C10. Soft start overheating	Default value: Trip to stop
	C11. Motor overheating	Default value: Ignore
	C12. Short circuit between phases	Default value: Trip to stop
	C13. Ground fault default	value: trip and stop
	C14. Phase sequence protection	Default value: Ignore
	C15. Thyristor breakdown	Default value: trip and stop
	C16. External fault	Default value: trip and stop
	C17. Frequency protection	Default value: Trip to stop

C. Protection level

D. Calibration function

D00.A phase current calibration value

Range: 10%-1000% Default value: 100%

Description: Calibrate the A-phase current monitoring circuit of the soft starter to match the external current measurement equipment.

Use the following formula to determine the necessary adjustment:

Calibration (%) = soft start external equipment measuring current / display current

For example, 102%=51A/50A



Notice:

This adjustment affects all current-based functions and protections.

D01.B phase current calibration value

Range: 10%-1000%

Default value: 100%

Description: Calibrate the B-phase current monitoring circuit of the soft starter to match the external current measurement equipment.

Use the following formula to determine the necessary adjustment:

Calibration (%) = soft start external equipment measuring current / display current

For example, 102%=51A/50A



Notice:

This adjustment affects all current-based functions and protections.

D02.C phase current calibration value

Range: 10%-1000%

Default value: 100%

Description: Calibrate the C-phase current monitoring circuit of the soft starter to match the external current measurement equipment.

Use the following formula to determine the necessary adjustment:

Calibration (%) = soft start external equipment measuring current / display current

For example, 102%=51A/50A



Notice:

This adjustment affects all current-based functions and protections.

D03. Input voltage calibration value

Range: 10%-1000% Default value: 100%

Description: Calibrate the input voltage monitoring circuit of the soft starter to match the external voltage measurement equipment.

Use the following formula to determine the necessary adjustment:

Calibration (%) = soft start external equipment measurement voltage / display voltage

For example, 102%=387.6V/380V



Note:

This adjustment affects all voltage-based functions and protections.

D04. Output voltage calibration value

Range: 10%-1000%

Default value: 100%

Description: Calibrate the output voltage monitoring circuit of the soft starter to match the external voltage measurement equipment.

Use the following formula to determine the necessary adjustment:

Calibration (%) = soft start external equipment measurement voltage / display voltage

For example, 102%=387.6V/380V

D05.4-20mA lower limit calibration

Range: 0%-150%

Default value: 20%

Note: Calibrate the lower limit of analog output. The default 20% means that the lower limit is 4mA. If it is set to 10%, the lower limit is 2mA.

D06. 4-20mA upper limit calibration

Range: 0%-150%

Default value: 100%

Note: Calibrate the upper limit of analog output. The default 100% means that the upper limit is 20mA. If it is set to 110%, the upper limit is 22mA.

E. Additional functions

E00. Programmable Relay 1

Options:

- | | |
|--|---|
| 0: No action Relay | A is not used. |
| 1: Power-on action | When the soft starter is powered on, the relay will act. |
| 2: Action during soft-start | When the soft starter is in the soft-start state, the relay will act. |
| 3: Bypass action | After the start, the soft starter will turn to the running state, and the relay will act. |
| 4: Action during soft stop | When the soft starter is in the soft stop state, the relay will act. |
| 5: Action during jogging | When the soft starter is in jogging state, the relay will act. |
| 6: Action during running | When the soft starter has output, the relay will act. |
| 7: Standby action | When the soft starter is in standby state, the relay will act. |
| 8: Fault action (default) | When the soft starter is in a fault state, the relay will act. |
| 9: Thyristor breakdown action | When the soft starter detects a current in the standby state, the relay will act. |
| 10: Current is greater than the reached value action 1 | |

If the soft starter's operating current is greater than the set value, the relay will act. Refer to the current reaching function for details.

- 11: Current is greater than the reached value action 2

When the soft starter's operating current is greater than the set value, the relay will act. Refer to the current reaching function for details.

- 12: Current is less than the reach value action 1

If the soft starter's operating current is less than the set value, the relay will act. Refer to the current reach function for details.

- 13: Current is less than the reached value action 2

When the soft starter's operating current is less than the set value, the relay will act. Refer to the current reaching function for details.

Description: Select programmable relay 1 function (1 open and 1 close).

E01. Programmable output delay 1

Range: 0S-600S

Default value: 0S

Description: Set the action delay of programmable relay 1. Setting it to 0 means it will act immediately without delay.

E02. Programmable Relay 2

Options:

- | | |
|--|---|
| 0: No action Relay | A is not used. |
| 1: Power-on action | When the soft starter is powered on, the relay will act. |
| 2: Action during soft-start | When the soft starter is in the soft-start state, the relay will act. |
| 3: Bypass action | After the start, the soft starter will turn to the running state, and the relay will act. |
| 4: Action during soft stop | When the soft starter is in the soft stop state, the relay will act. |
| 5: Action during jogging | When the soft starter is in jogging state, the relay will act. |
| 6: Action during running (default) | When the soft starter has output, the relay will act. |
| 7: Standby action | When the soft starter is in standby state, the relay will act. |
| 8: Fault action | When the soft starter is in a fault state, the relay will act. |
| 9: Thyristor breakdown action | When the soft starter detects a current in the standby state, the relay will act. |
| 10: Current is greater than the reached value action 1 | |

If the soft starter's operating current is greater than the set value, the relay will act. Refer to the current reaching function for details.

- 11: Current is greater than the reached value action 2

When the soft starter's operating current is greater than the set value, the relay will act. Refer to the current reaching function for details.

- 12: Current is less than the reach value action 1

If the soft starter's operating current is less than the set value, the relay will act. Refer to the current reach function for details.

- 13: Current is less than the reached value action 2

When the soft starter's operating current is less than the set value, the relay will act. Refer to the current reaching function for details.

Description: Select programmable relay 2 function (1 open and 1 close).

E03. Programmable output delay 2

Range: 0S-600S

Default value: 0S

Description: Set the action delay of programmable relay 2. Setting it to 0 means it will act immediately without delay.

E04. Current reaches 1

Range: 1%-600% of rated current

Default value: 100%

Explanation: Set the current reaching value during soft start operation, which is the percentage of the rated current of the motor.

E05. Current arrival hysteresis 1

Range: 1%-100% rated current

Default value: 20%

Explanation: Set the current hysteresis value during soft start operation, which is the percentage of the motor's rated current.

E06. Current reaches 2

Range: 1%-600% of rated current

Default value: 70%

Explanation: Set the current reaching value during soft start operation, which is the percentage of the rated current of the motor.

E07. Current arrival hysteresis 2

Range: 1%-100% rated current

Default value: 20%

Explanation: Set the current hysteresis value during soft start operation, which is the percentage of the motor's rated current.

E08. 4-20mA function selection

Options: 0: Output current (default) 1: Start percentage 2: Soft starter temperature 3: Motor temperature

Note: Select the analog output type. When 2 is selected, 20mA corresponds to 120°C, and when 3 is selected, 20mA corresponds to 100°C.

E09. 4-20mA upper limit current

Range: 50%-500% rated current

Default value: 200%

Note: Select the current value of the analog output corresponding to the rated current. The default 200% is 20mA corresponding to 200% of the rated current.

E10. External control start-stop mode

Options: 0: Level mode (default) 1: Pulse mode

Note: Select whether to short-circuit the stop and common when the external control starts and stop, the default is to short-circuit, and it cannot be started if it is not short-circuited.

E11. Motor connection method

Options: 0: Line (default)

1: Inner triangle

Description: Select the motor connection method.

E12. Communication protocol selection

Options: 0: No communication

1: ModbusRTU (default)

Description: Choose to open or close the communication mode.

E13. Mailing address

Range: 1-127

Default value: 1

Description: Used for multi-machine communication between multiple soft starters and upper computer.

E14. Communication baud rate

Options: 0: 2400 1: 4800 2: 9600 (default) 3: 19200

Description: Select the data transmission rate in the communication mode.

E15. Reserved

Description: Reserved.

E16. Parameter setting password

Range: 00000-65535

Default value: 00000

Description: Set the password for the user to enter the parameter modification interface, 00000 means no password.

F. Status information

Options:

F00. Rated current of soft start	Description: The rated working current of soft start cannot be modified.
F01. Rated voltage of soft start	Description: The rated working voltage of soft start cannot be modified.
F02. Motor rated current	Description: The user can adjust it appropriately according to the size of the motor.
F03. Average current	Description: Display the three-phase average current of the current soft start work.
F04. Input voltage	Description: Display the current input voltage of soft start.
F05. Output voltage	Description: Display the current output voltage of soft start.
F06. A-phase current value	Description: Display the current A-phase current of soft start work.
F07. B-phase current value	Description: Display the current B-phase current of soft start work.
F08. C-phase current value	Description: Display the current C-phase current of soft start work.
F09. Start completion percentage	Description: Display the current start completion percentage of soft start.
F10. Three-phase current unbalance degree	Description: The ratio of the difference between the phase with the largest difference from the average current and the average current.
F11. Apparent power	Description: Display the current working power of the motor
F12. Power frequency	Description: Display the current input power frequency of soft start.
F13. Power phase sequence	Description: Display the phase sequence of the current soft start input power.
F14. Radiator temperature	Description: Display the current radiator temperature for soft start.
F15. Motor temperature	Description: Display the current temperature of the motor.
F16. Soft start times	Description: Display the current total number of soft starts.
F17. Cumulative running time	Description: Display the total running time of the current soft start.
F18. Current running time	Description: Display the running time of the current soft starter this time.
F19. Real-time time	Description: year/month/day/hour/minute/second, can be modified.
F20. Main control software version	Description: Display the current soft start software version.

G. Display parameters

G00. Standby display mode

Options: 0: Default (default) 1: Custom

Description: View the 6.2 display in detail.

G01. Operation display mode

Options: 0: Default (default) 1: Custom

Description: View the 6.2 display in detail.

G02. The upper left corner of the screen

Options:

0: Blank	1: Soft start state (default)	2: Control mode
3: Soft start mode	4: Input voltage	5: Output voltage
6: Soft start percentage	7: radiator temperature	8: motor temperature
9: Number of motor starts	10: Current running time	11: Power frequency
12: Power phase sequence		

Description: Select the parameter displayed in the upper left corner of the screen.

G03. The upper right corner of the screen

Options:

0: Blank	1: Soft start state	2: Control mode
3: Soft start mode	4: Input voltage (default)	5: Output voltage
6: Soft start percentage	7: radiator temperature	8: motor temperature
9: Number of motor starts	10: Current running time	11: Power frequency
12: Power phase sequence		

Description: Select the parameter displayed in the upper right corner of the screen.

G04. The lower left corner of the screen

Options:

0: Blank	1: Soft start state	2: Control mode
3: Soft start mode (default)	4: Input voltage	5: Output voltage
6: Soft start percentage	7: radiator temperature	8: motor temperature
9: Number of motor starts	10: Current running time	11: Power frequency
12: Power phase sequence		

Description: Select the parameter displayed in the lower left corner of the screen.

G05. The bottom right corner of the screen

Options:

0: Blank	1: Soft start state	2: Control mode
3: Soft start mode	4: Input voltage	5: Output voltage
6: Soft start percentage (default)	7: radiator temperature	8: motor temperature
9: Number of motor starts	10: Current running time	11: Power frequency
12: Power phase sequence		

Description: Select the parameter displayed in the lower right corner of the screen.

G. Display parameters

G00. Standby display mode

G06. Operation language selection

Options: 0: English 1: Chinese (default)

Description: Select the language for displaying messages and feedback on the operation panel.

G07. Screen saver time

Range: 0S-1800S

Default value: 120S

Note: Select the screen saver time, the backlight will be turned off when overtime, 0 means turn off this function

G08. Keyboard software version

Description: Display the software version of the current soft start operation panel.

Chapter 10 Troubleshooting

10.1 Protection response

When the protection condition is detected, the soft starter writes the protection condition into the program, and it may trip or issue a warning. Soft starter response depends on Parameter setting C. Protection level.

The user cannot adjust some of these protection responses. These trips are usually caused by external events (such as phase loss), and may also be caused by internal faults in the soft starter.

Into. These trips have no relevant parameters and cannot be set as warning or ignored.

If the soft starter trips, you need to identify and clear the conditions that triggered the trip, reset the soft starter, and then restart. To reset the starter, you need

Press the RESET button on the operation panel, or activate "Reset Remote Input".

10.2 Trip message

The following table lists the protection mechanism of the soft starter and possible trip reasons. Some settings can be adjusted with parameter C. Protection level, while other settings are built-in systemsProtection cannot be set or adjusted.

Serial number	Fault name	Possible Causes	Suggested solution	Remark
01	Input phase loss	1. Issue start command type, soft start One or more phases are not energized. 2. The main board of the circuit board is faulty.	1. Check whether the main circuit has electricity 2. Check the inputWhether the circuit thyristor is open, pulse signal lineWhether the contact is bad. 3. Seek help from the manufacturer.	This trip does not adjustable
02	Output phase loss	1. Whether the SCR is short-circuited. 2. Motor One or more phases of the line are open. 3. Line the main board of the circuit board is faulty.	1. Check whether the SCR is short-circuited. 2. Check whether the motor wire is open. 3. Seek help from the manufacturer.	This trip does not adjustable
03	Running overload	1. The load is too heavy. 2. Improper parameter settings	1. Replace the soft starter with more power. 2. Adjust the parameters.	Related parameters: B01, C01
04	Starting overload	1. The load is too heavy. 2. Improper parameter settings	1. Replace the soft starter with more power. 2. Adjust the parameters.	Related parameters: B00, C00
05	Underload	1. The load is too small. 2. Improper parameter settings	1. Adjust the parameters.	Related parameters: B14, B15, C9
06	Current imbalance	1. The power supply voltage is unbalanced. 2. Motor windingThere is a problem with the group. 3. There is a problem with the transformer.	1. Check the power supply voltage. 2. Check the motor windings. 3. Check whether the transformer is open.	Related parameters: B10, B11, C06
07	Soft overheating	1. The temperature switch is faulty. 2. The fan does not rotate. 3. The working time of soft start is too long.	1. Check whether the temperature switch is faulty. 2. CheckWhether the fan is working normally. 3. Stop the machine,Let the soft start cool down.	Related parameters: C10
08	Overpressure	1. The input power supply voltage is too high. 2. Improper parameter settings.	1. Check the power supply voltage. 2. Adjust the parameters.	Related parameters: B06, B07, C04
09	Undervoltage	1. The input power supply voltage is too low. 2. Improper parameter settings.	1. Check the power supply voltage. 2. Adjust the parameters.	Related parameters: B08, B09, C05
10	Thyristor breakdown	1. The input power supply voltage is too low. 2. Improper parameter settings.	1. Check the power supply voltage. 2. Adjust the parameters.	Related parameters: C15

Troubleshooting

Serial number	Fault name	Possible Causes	Suggested solution	Remark
11	Istart timeout	1. The power supply capacity is not enough. 2. LoadToo heavy. 3. Improper parameter settings.	1. Adjust the parameters.	Related parameters: A02,A12, C07
12	Jog timeout	1. Parameter setting.	1. Adjust the parameters.	Related parameters: B13, C08
13	Running overcurrent	1. The load is too heavy. 2. Improper parameter settings	1. Replace the soft starter with more power. 2. Adjust the parameters.	Related parameters: B04,B05, C01
14	Starting overcurrent	1. The load is too heavy. 2. Improper parameter settings	1. Replace the soft starter with more power. 2. Adjust the parameters.	Related parameters: B02,B02, C02
15	Motor overheated	1. The motor has been working for too long. 2. The motor is damaged.	1. Let the motor cool down naturally. 2. Seek professionals to check the electrodes.	Related parameters: C11
16	External fault	1. External fault terminal has input	1. Check whether there is input at the external terminal.	Related parameters: C16
17	Power frequency is too high	1. The input power frequency is too high. 2. Improper parameter settings.	1. Check the power frequency. 2. Adjust the parameters.	Related parameters: B17,B19,C17
18	Power frequency is too low	1. The input power frequency is too high. 2. Improper parameter settings.	1. Check the power frequency. 2. Adjust the parameters.	Related parameters: B18,B19,C17
19	Phase sequence failure	1. Input power phase sequence and The settings are inconsistent.	1. Check the power frequency. 2. Adjust the parameters.	Related parameters: B16,C14

Chapter 11 Function Description

11.1 Overload protection

Overload protection adopts inverse time limit control

$$\text{Guard time: } t = \frac{35 * T_p}{(I / I_p)^2 - 1}$$

Among them: t represents the operating time, T_p represents the protection level, I represents the operating current, I_p represents the motor rated current

Motor overload protection characteristic curve: Figure 11-1

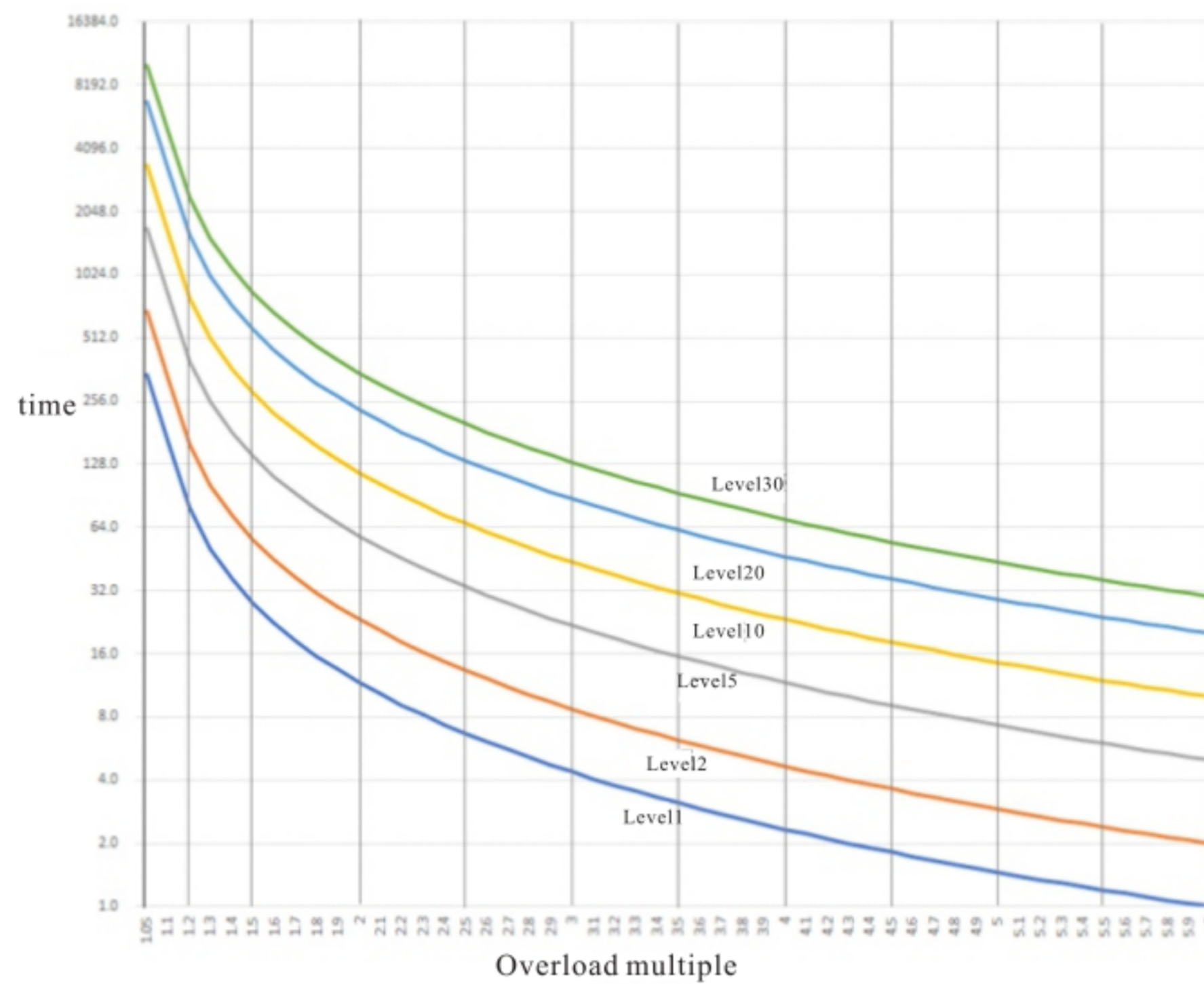

Motor overload protection characteristics

overload level \ overload multiple	1.05Ie	1.2Ie	1.5Ie	2Ie	3Ie	4Ie	5Ie	6Ie
1	∞	79.5s	28s	11.7s	4.4s	2.3s	1.5s	1s
2	∞	159s	56s	23.3s	8.8s	4.7s	2.9s	2s
5	∞	398s	140s	58.3s	22s	11.7s	7.3s	5s
10	∞	795.5s	280s	117s	43.8s	23.3s	14.6s	10s
20	∞	1591s	560s	233s	87.5s	46.7s	29.2s	20s
30	∞	2386s	840s	350s	131s	70s	43.8s	30s

∞: Indicates no action

11.2 Current arrival

The current arrival function is used with two multi-function relays, and it is divided into two modes: the current is greater than the reached value and the current is less than the reached value.

In the action mode where the current is greater than the reached value, the relay will act when the operating current is greater than the current reaching the set value, and when the operating current is less than (current reached value - electric When the flow reaches the return difference), the relay recovers, as shown in Figure 11-2.

In the action mode where the current is less than the reached value, the relay will act when the operating current is less than the current reaching the set value, and when the operating current is greater than (current reached value + electric When the flow reaches the return difference), the relay will recover, as shown in Figure 11-3.

The parameters related to the current arrival function are:

Programmable relay 1, programmable output delay 1, programmable relay 2,
 Programmable output delay 2, current reaches 1, current reaches hysteresis 1,
 The current reaches 2, the current reaches the hysteresis 2

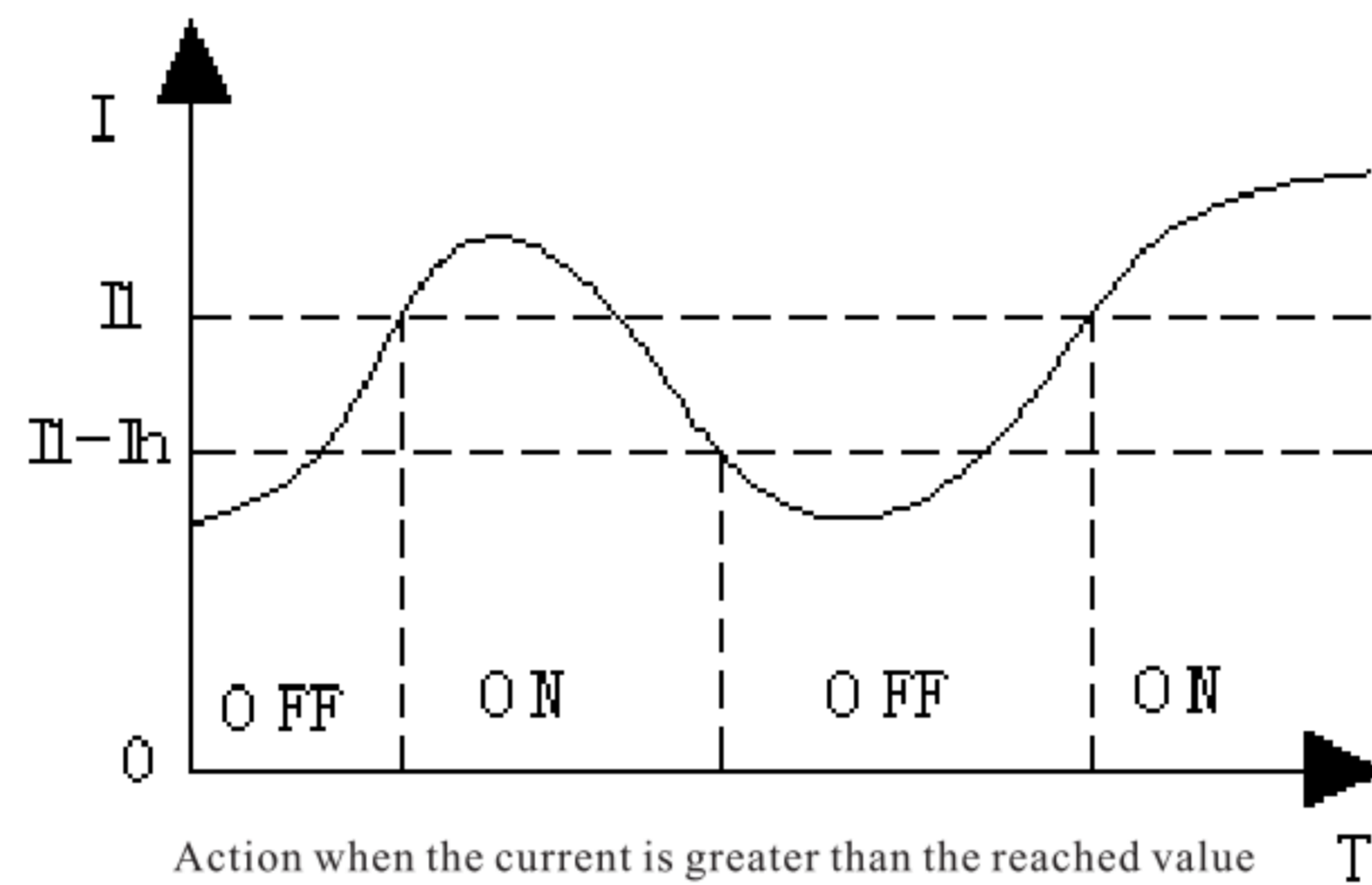

Figure 11-2

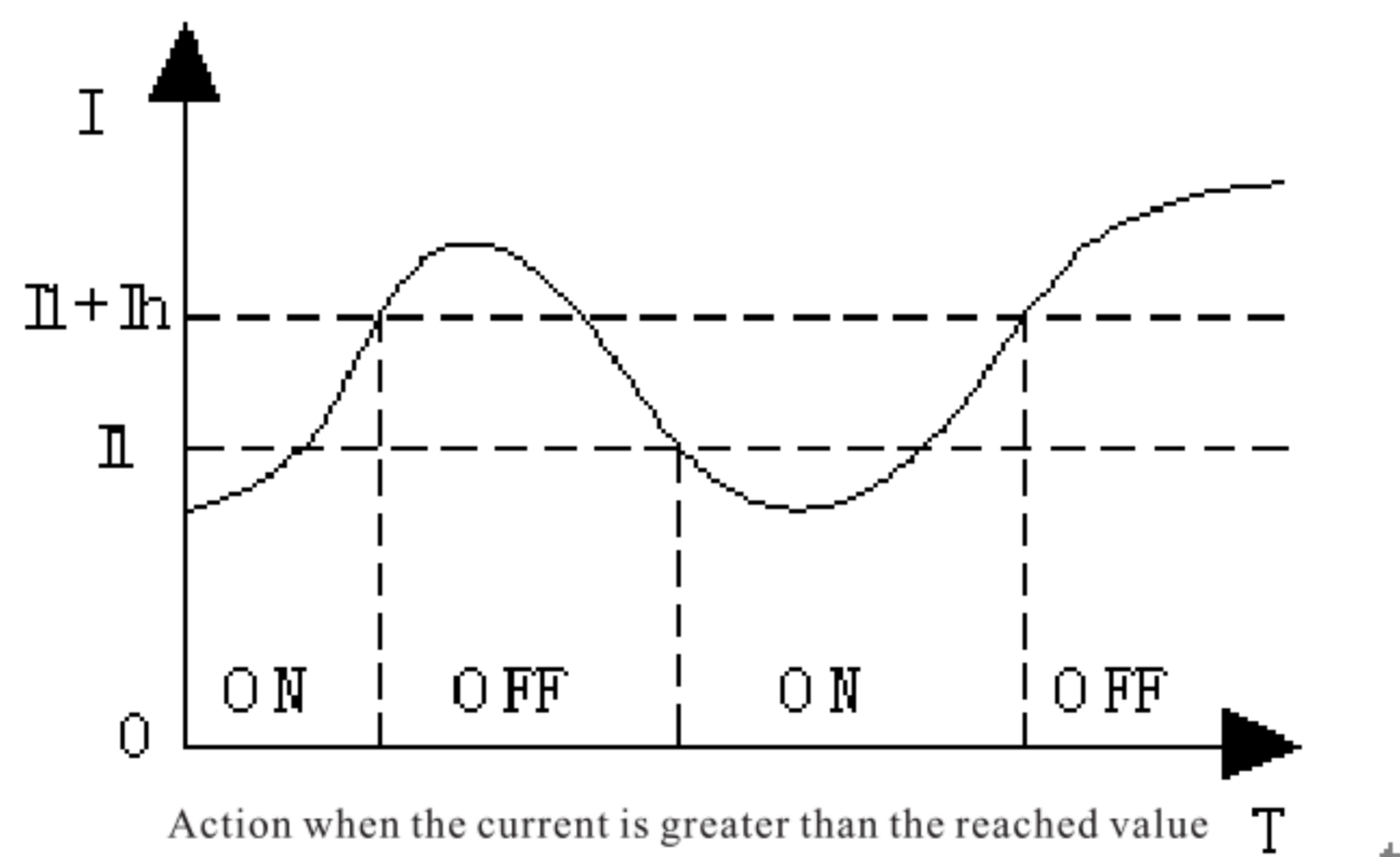

Figure 11-2

In the figure: II represents the current reached value, I_h represents the hysteresis current, ON means that the relay is activated, and OFF means that the relay is restored.

Chapter 12 Appendix

12.1 Specifications

Model code

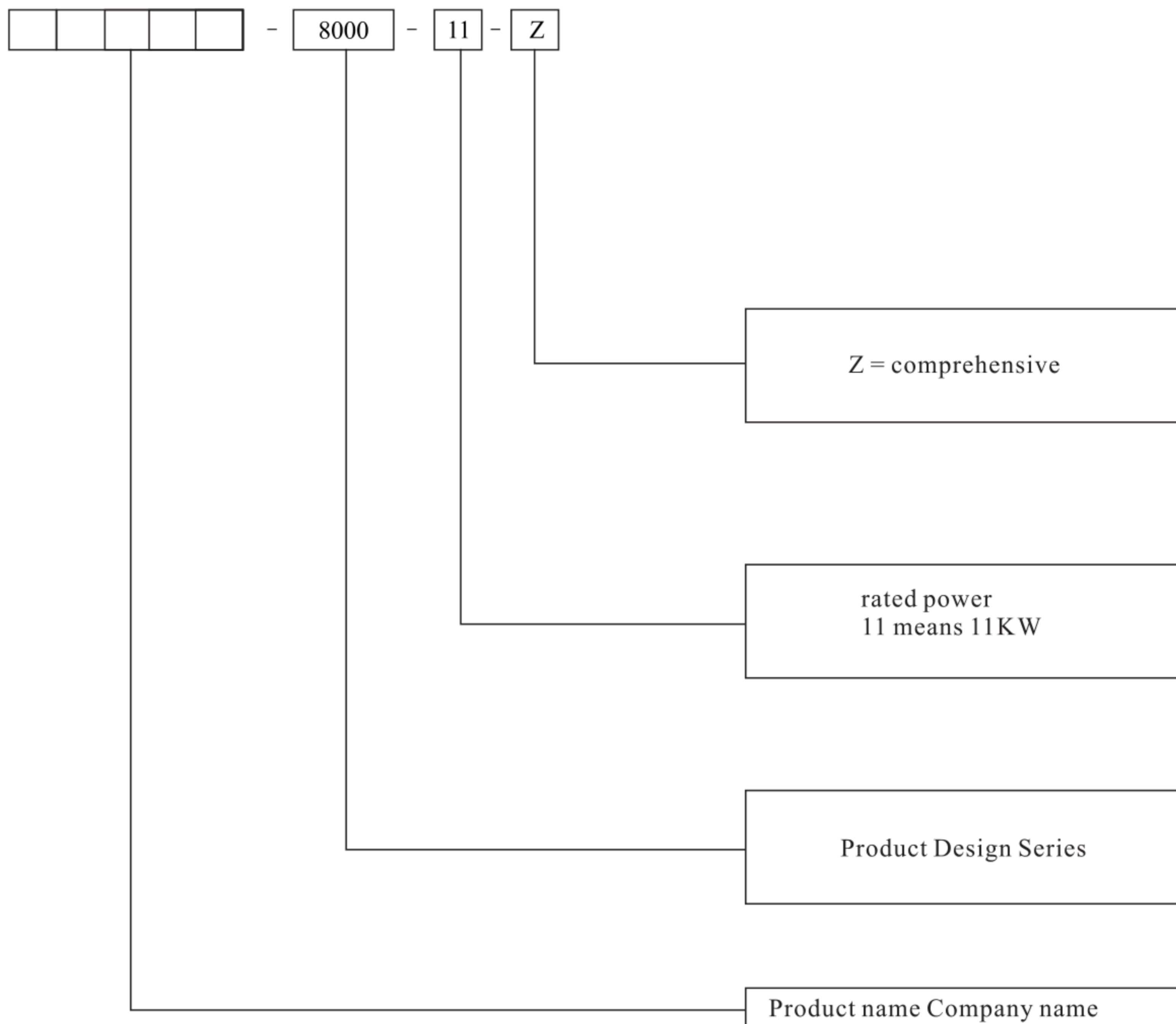

Minimum current and maximum current setting

The minimum rated current setting and maximum rated current setting of the soft starter depend on the model:

model	Star connection	Triangle connection
8000-011-Z	22A	37A
8000-015-Z	30A	51A
8000-018-Z	37A	60A
8000-022-Z	44A	74A
8000-030-Z	60A	102A
8000-037-Z	74A	126A
8000-045-Z	90A	150A
8000-055-Z	110A	180A
8000-075-Z	150A	255A
8000-090-Z	180A	306A
8000-110-Z	220A	370A
8000-115-Z	230A	391A
8000-132-Z	264A	448A
8000-160-Z	320A	544A
8000-185-Z	370A	629A
8000-200-Z	400A	680A
8000-220-Z	440A	748A
8000-250-Z	500A	850A
8000-280-Z	560A	952A
8000-320-Z	640A	1088A
8000-350-Z	700A	1190A
8000-400-Z	800A	1360A
8000-450-Z	900A	1530A
8000-500-Z	1000A	1700A

Size and weight

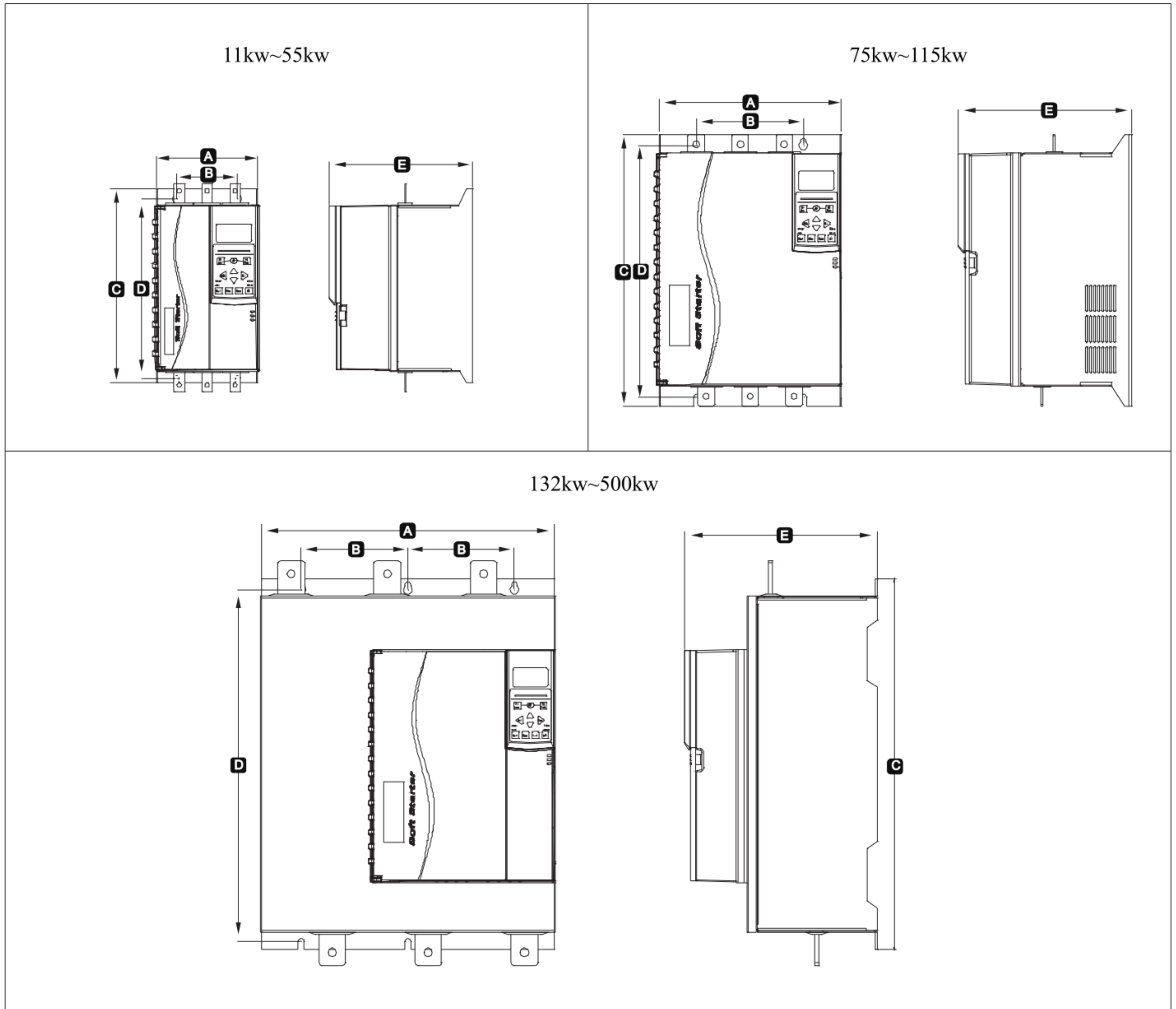

Model	A mm	B mm	C mm	D mm	E mm	F mm	G mm	H mm	Weight kg
11kw~55kw	152	92	292	269	215	Not applicable	Not applicable	Not applicable	5.2
75kw~115kw	274	160	408	385	260	Not applicable	Not applicable	Not applicable	17.5
132kw~500kw	440	320 (160*2)	530	530	290	Not applicable	Not applicable	Not applicable	35.5

