

# 3-Phase EMC/EMI output Filter 三相输出滤波器

三相输出滤波器  
3-Phase EMC/EMI output Filter



## Product Profile 产品简述

This category of products has superior capability of interference containment and can be applied to data processing system, telecommunication equipment inverter and power conditioning equipment that impose high requirement on interference containment.

该类产品具有良好的干扰抑制能力，可用于数据处理系统、电信系统、变频器及电源净化等需要强干扰抑制器设备中。

## Product Parameters 产品参数

Rated Voltage:	AC 380-440V
Test Voltage (1 minute):	Phase to Phase DC 1500V; Phase To Ground AC 1500V/DC 2500V
Operating Frequency:	50/60Hz
Range of Temperature:	-25°C ~ 85°C
Insulation Resistance:	Phase to ground (up to 300A) ≥ 1500MΩ

额定电压:	AC 380-440V
试验电压 (1分钟):	线至线DC 1500V; 线至地AC 1500V/DC 2500V
工作频率:	50/60Hz
范围温度:	-25°C ~ 85°C
绝缘电阻:	线至地 (300A以下) ≥ 1500MΩ

## Electrical Diagram 电气原理图

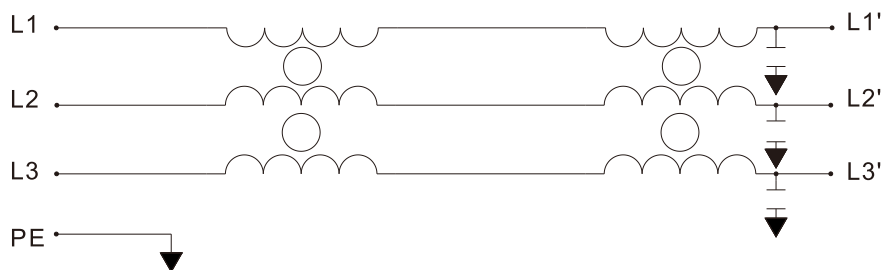

## Product Size 产品尺寸图

All dimensions in mm; 1 inch = 25,4 mm

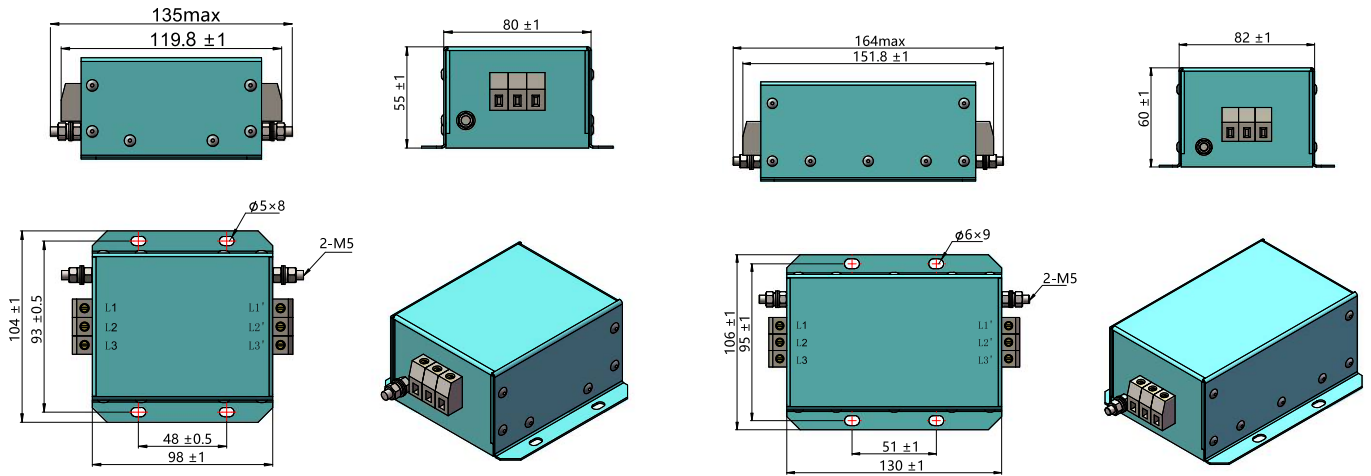

Fig. A

Fig. B

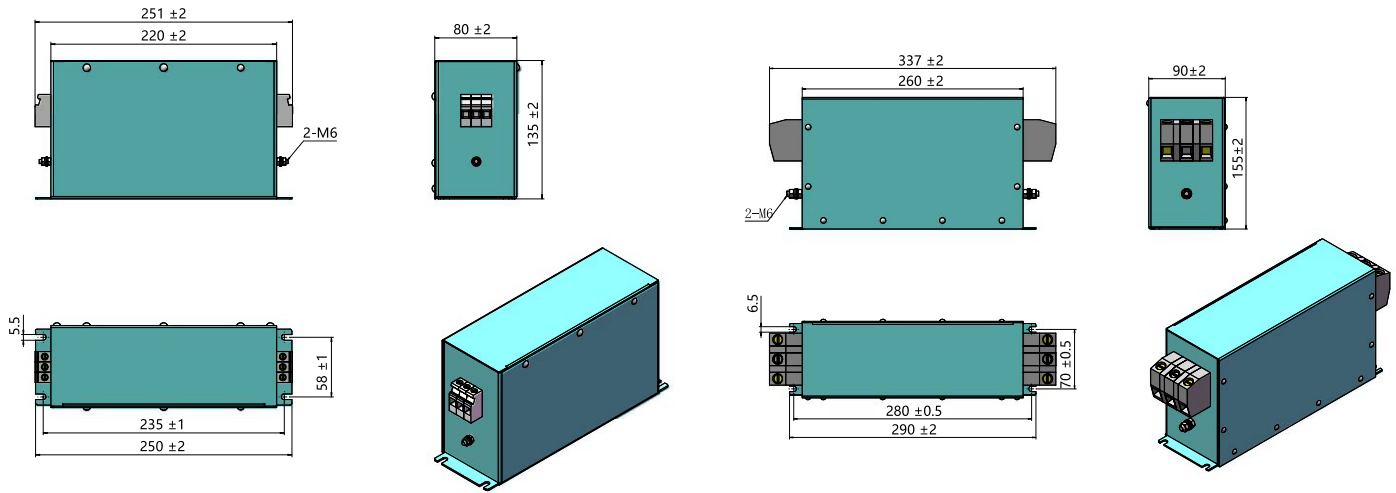

Fig. C

Fig. D

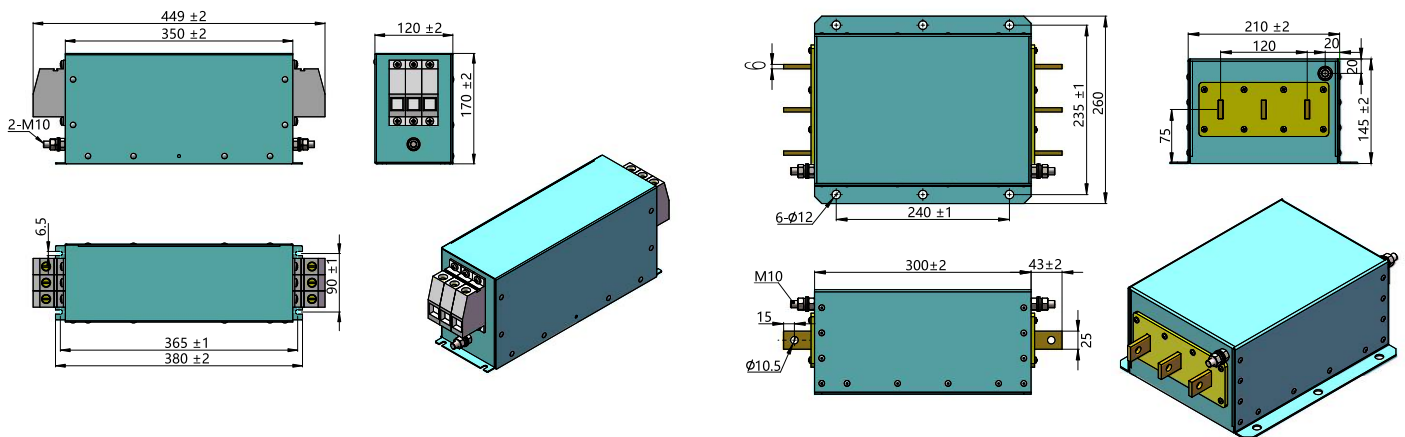

Fig. E

Fig. F

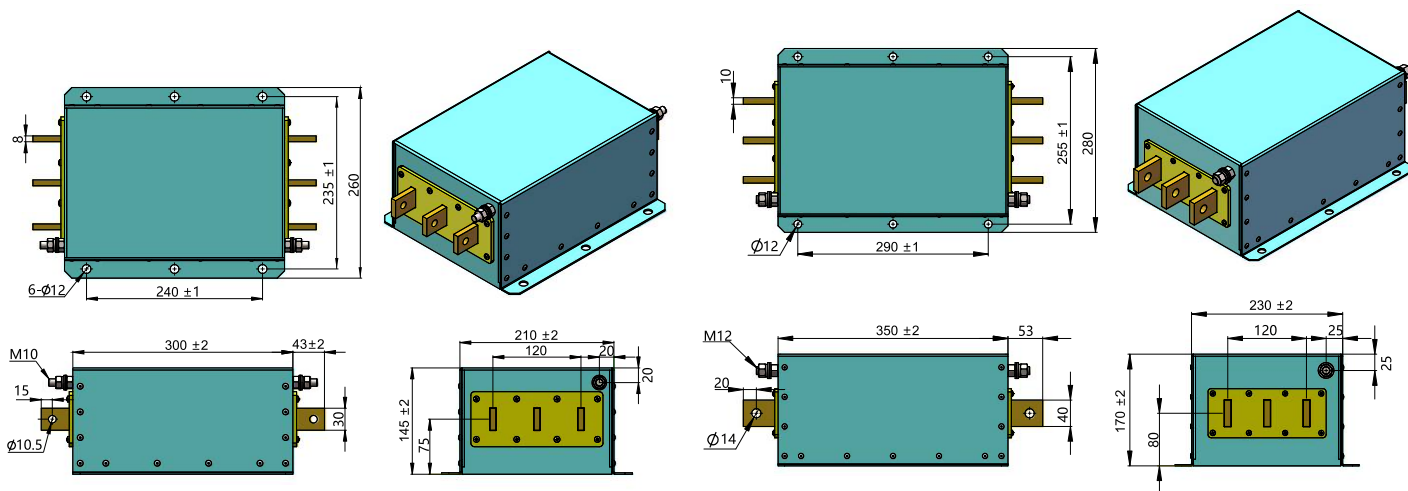

Fig. G

Fig. H

### Selection Table

Type	Dimension Fig.	Rated Current (A)	Power (Kw)	Rated Voltage	Leakage Current (mA)	Connection Mode	Insulation Resistance	Weight (kg)
EFO-0005/4-T	Fig. A	5	0.75-1.5	AC440/250V	≤0.8	Terminals	≥500(MΩ)	0.75
EFO-0010/4-T	Fig. A	10	2.2-3.7	AC440/250V	≤0.8	Terminals	≥500(MΩ)	0.75
EFO-0016/4-T	Fig. B	16	5.5	AC440/250V	≤0.8	Terminals	≥500(MΩ)	1.2
EFO-0020/4-T	Fig. B	20	7.5	AC440/250V	≤0.8	Terminals	≥500(MΩ)	1.2
EFO-0030/4-T	Fig. C	30	11	AC440/250V	≤1.2	Terminals	≥500(MΩ)	2.8
EFO-0045/4-T	Fig. C	45	15	AC440/250V	≤1.2	Terminals	≥500(MΩ)	3.0
EFO-0050/4-T	Fig. C	50	18.5	AC440/250V	≤1.2	Terminals	≥500(MΩ)	3.0
EFO-0060/4-T	Fig. C	60	22	AC440/250V	≤1.2	Terminals	≥500(MΩ)	3.0
EFO-0070/4-T	Fig. D	70	30	AC440/250V	≤1.5	Terminals	≥500(MΩ)	4.5
EFO-0080/4-T	Fig. D	80	37	AC440/250V	≤1.5	Terminals	≥500(MΩ)	4.5
EFO-0100/4-T	Fig. D	100	45	AC440/250V	≤1.5	Terminals	≥500(MΩ)	4.5
EFO-0120/4-T	Fig. D	120	55	AC440/250V	≤1.8	Terminals	≥500(MΩ)	4.5
EFO-0150/4-T	Fig.E	150	75	AC440/250V	≤1.8	Terminals	≥500(MΩ)	7.5
EFO-0200/4-T	Fig.E	200	90	AC440/250V	≤1.8	Terminals	≥500(MΩ)	8.2
EFO-0300/4-C	Fig.F	300	110-160	AC440/250V	≤2.5	Copper bar	≥500(MΩ)	14.5
EFO-0400/4-C	Fig.F	400	185-200	AC440/250V	≤2.5	Copper bar	≥500(MΩ)	15.0
EFO-0500/4-C	Fig.G	500	220-250	AC440/250V	≤2.5	Copper bar	≥500(MΩ)	16.3
EFO-0600/4-C	Fig.G	600	280-315	AC440/250V	≤2.5	Copper bar	≥500(MΩ)	16.3
EFO-0800/4-C	Fig.H	800	350-450	AC440/250V	≤2.5	Copper bar	≥500(MΩ)	24.0
EFO-1000/4-C	Fig.H	1000	500	AC440/250V	≤2.5	Copper bar	≥500(MΩ)	24.0
EFO-1200/4-C	Fig.H	1200	550-630	AC440/250V	≤2.5	Copper bar	≥500(MΩ)	24.0

Model Rules:

□□□□-□□□□/□

Rated Voltage (2 for 220V,4 for 400V)

Rated current

Series name

Note: The insertion loss is measured by IEC/CISPR 17 under the no-load 50Ω-50Ω test system. The final effect is based on the actual working condition data.

—— Common Mode  
 - - - - - Differential Mode

5 ~ 20A

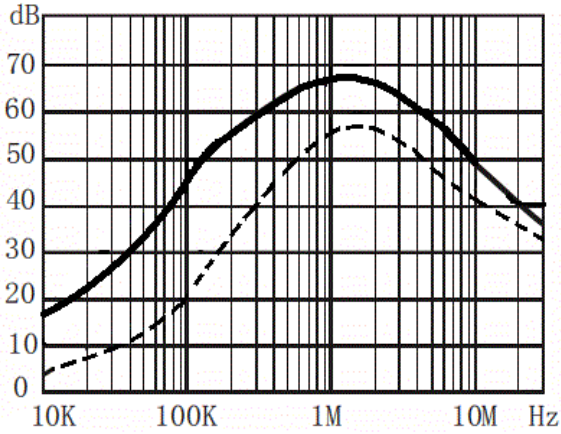

25 ~ 65A

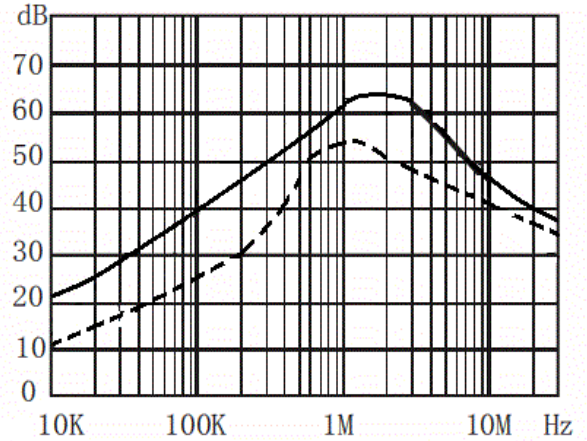

70 ~ 130A

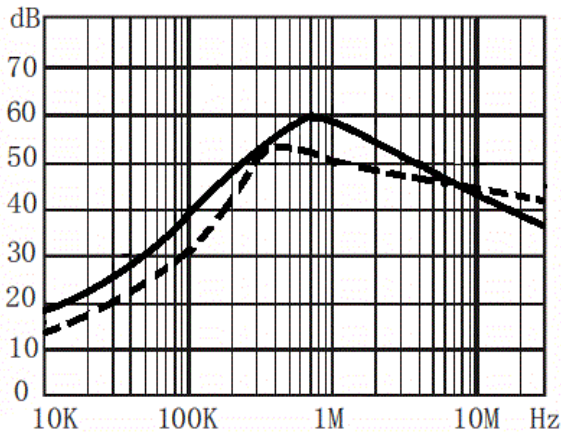

150 ~ 200A

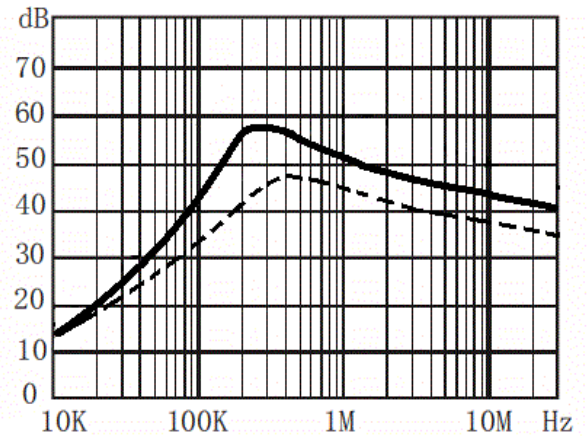

250 ~ 650A

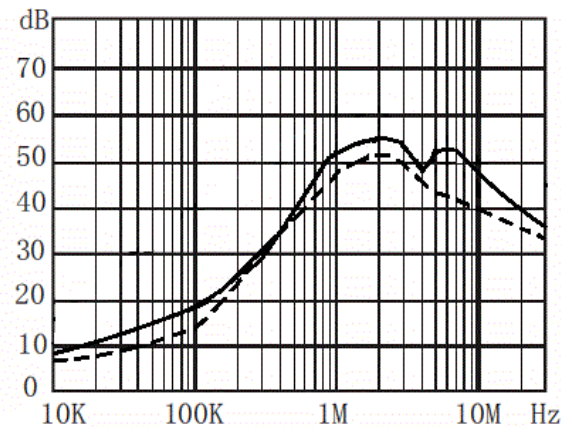

700 ~ 1200A

